



RESOLUTION No. 23-576

OF THE BOARD OF SUPERVISORS OF THE COUNTY OF NEVADA

RESOLUTION APPROVING THE BID CONSTRUCTION DOCUMENTS AND SPECIFICATIONS FOR THE NEVADA COUNTY BRUNSWICK COMMONS RESOURCE CENTER PROJECT, AUTHORIZING THE BOARD CHAIR TO SIGN THE DOCUMENTS, AND DIRECTING THE PURCHASING AGENT TO SOLICIT BIDS

WHEREAS, the Board authorized the purchase of the property located at 1105 Sutton Way, Grass Valley CA for the purpose of providing homeless services on August 23, 2022, per Resolution 22-464; and

WHEREAS, the Housing and Community Services Division was awarded Planning and Technical Assistance grant 20-CDBG-12032 from the California Department of Housing and Community Development's Community Development Block Grant Program to obtain Architectural Services; and

WHEREAS, the Board approved Wallis Design Studios to prepare the plans and specifications for the facility design on January 24, 2023, per Resolution 23-038; and

WHEREAS Nevada County Health and Human Services has obtained funding for the construction of the facility renovations; and

WHEREAS, the Housing and Community Services Division has prepared construction documents for the project known as the Brunswick Commons Resource Center Project; and

WHEREAS, funding for this project is a combination of grant sources in Health and Human Services fund balance. These funds are within the department budgets and no general fund is required in this agreement; and

WHEREAS, the attached plans are under review by the City of Grass Valley Building Department and are expected to be approved in substantial conformity to the attached.

NOW, THEREFORE, BE IT RESOLVED that the Board of Supervisors of the County of Nevada, State of California, hereby:

1. Approves the bid construction documents and specifications for Brunswick Commons Resource Center Project in substantial conformity to the attached.
2. Authorizes the Chair of the Board of Supervisors to sign the documents upon final approval of the City of Grass valley Building Department.
3. Directs the Purchasing Agent to solicit bids for this project.

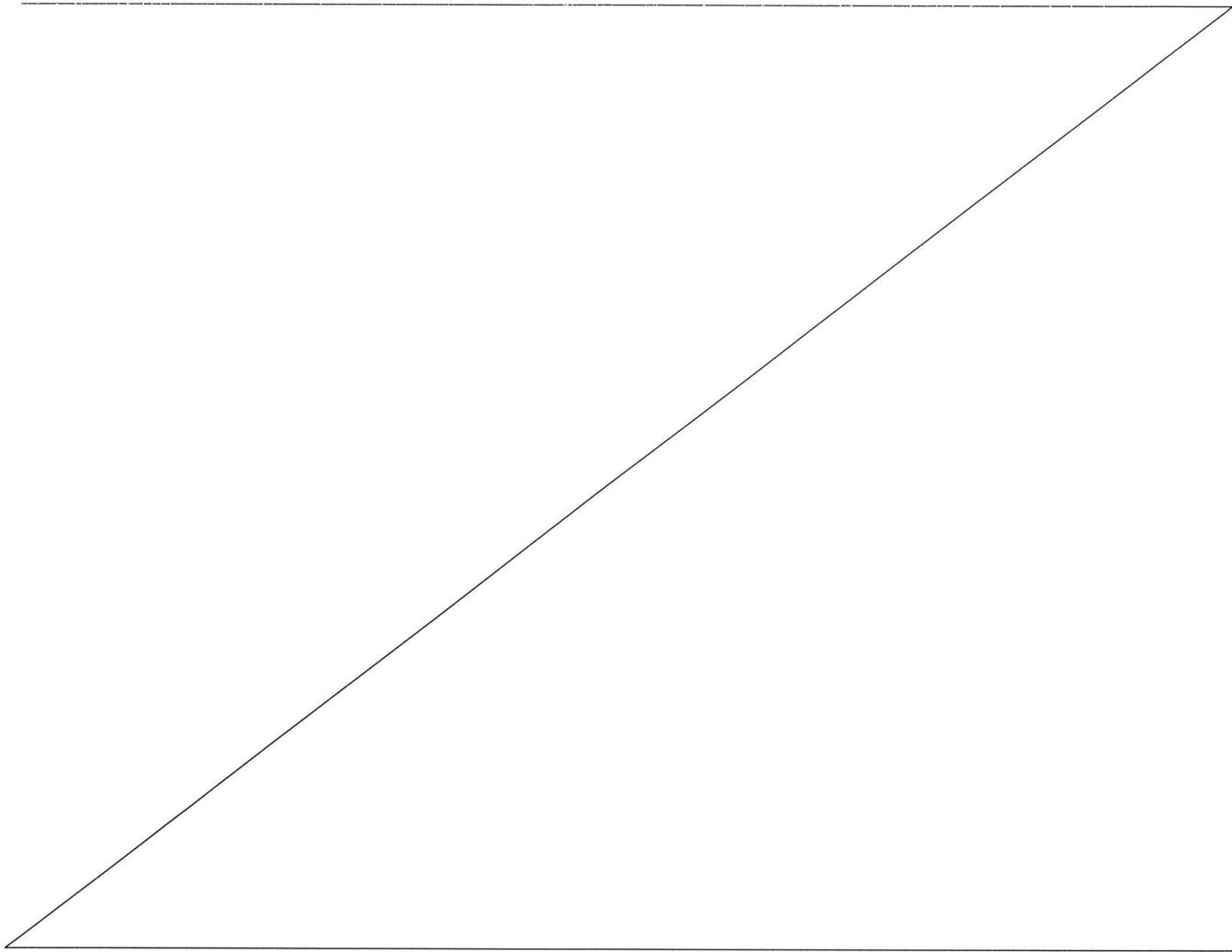

PASSED AND ADOPTED by the Board of Supervisors of the County of Nevada at a regular meeting of said Board, held on the 5th day of December, 2023, by the following vote of said Board:

Ayes: Supervisors Heidi Hall, Edward C. Scofield, Lisa Swarthout,
Susan Hoek and Hardy Bullock.
Noes: None.
Absent: None.
Abstain: None.

ATTEST:

JULIE PATTERSON HUNTER
Clerk of the Board of Supervisors

For
By: Heidi Hall, Dep. An. COS

Edward C. Scofield
Edward C. Scofield, Chair

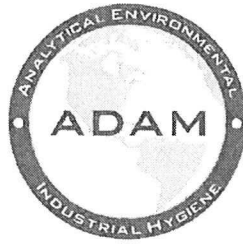

AdamLabs, Inc.

3807 Pasadena Avenue, Suite 190
Sacramento, CA 95821
Phone: (916) 692-8355
info@adamlabs.com

Lead Report

Date: *October 16, 2023*

Client: *Nevada County Housing & Community*

Site: *1105 Sutton Way
Grass Valley, CA*

The materials tested at the site above are not classified as Lead based Paint according to The State of California Department of Public Health (CDPH).

CDPH, Title 17 CCR Division 1 Chapter 8 Article 1 Definition 35033 establish the following: Surface coatings containing an amount of lead equal to, or excess of 5000 ppm, 0.5 % by weight or 1.0 mg/cm² by definition is "Lead Based Paint".

However, in addition to CDPH, Cal/OSHA and Cal/EPA are also other agencies that develop and enforce California regulations regarding worker safety and health. Housing and Urban Development (HUD) developed "Interim Guidelines" and "HUD Guidelines" which set standard of practice for lead-paint inspections, risk assessment, abatement and clearance.

Although CDPH lead worker certification is not required at lead levels below 5000 ppm, **OSHA regulates lead in any quantifiable amount;** no percent or weight amount is

defined in the OSHA standards. Cal/OSHA uses the EPA definitions of Lead paint to trigger the notifications portions of the Cal/OSHA standard.

The proposed work activities involve preparing surfaces to be re-painted. When removing paint containing lead, the following worker precautions should be implemented:

1. Worker must have 8 hours of "Lead Awareness training" within 12 months.
2. Use respirators with NIOSH approved HEPA filters.
3. Use Disposable clothing with head and foot covering.
4. 6 mil poly sheeting and/or drop cloth placed below work activities extending 8 feet out.
5. Lead Hazard Barrier tape at perimeter of work area approx. 15 feet out.
6. Clean the work area by use of a vacuuming equipped with a HEPA filter.
7. After completion, a final clearance / inspection and testing is recommended.

A representative of AdamLabs Inc collected the samples. The lead sample collection at this site was a limited evaluation to determine the presence of Lead. The Lead concentrations, materials, and their location can be found on the corresponding analytical laboratory results data sheet.

Approved by,



Adam Jahnsen, State Certified Department of Public Health (DHS #2364)

This is filed under 23PB2759.



Environmental Hazards Services, L.L.C.
 7469 Whitepine Rd
 Richmond, VA 23237
 Telephone: 800.347.4010

Lead Paint Chip
 Analysis Report

Report Number: 23-10-02790

Client: Adam Labs Inc.
 3807 Pasadena Ave. #190
 Sacramento, CA 95821

Received Date: 10/19/2023
 Analyzed Date: 10/19/2023
 Reported Date: 10/19/2023

Project/Test Address: 1105 Sutton; Grass Valley
 Collection Date: 10/16/2023

Client Number:
 05-5658

Laboratory Results

Fax Number:
 916-979-9251

Lab Sample Number	Client Sample Number	Collection Location	Pb (ug/g) ppm	% Pb by Wt.	Narrative ID
23-10-02790-001	1	CTR PONY WALL	<140	<0.014	L03
23-10-02790-002	2	S CTR OFFICE WALL	<90	<0.0090	
23-10-02790-003	3	CTR RM E WALL	<44	<0.0044	
23-10-02790-004	4	CTR W RM WALL	<75	<0.0075	

Environmental Hazards Services, L.L.C

Client Number: 05-5658
Project/Test Address: 1105 Sutton; Grass Valley

Report Number: 23-10-02790

Lab Sample Number	Client Sample Number	Collection Location	Pb (ug/g) ppm	% Pb by Wt.	Narrative ID
-------------------	----------------------	---------------------	---------------	-------------	--------------

Sample Narratives:

L03: Sample submitted was less than the recommended amount. A minimum of 0.1 grams should be submitted.

Preparation Method: ASTM E-1979-17
Analysis Method: EPA SW846 7000B

Reviewed By Authorized Signatory: Melissa Kanode

Melissa Kanode
QA/QC Clerk

The Reporting Limit (RL) for samples prepared by ASTM E-1979-17 is 10.0 ug Total Pb. The RL for samples prepared by EPA SW846 3050B is 25.0 ug Total Pb. Paint chip area and results are calculated based on area measurements determined by the client. All internal quality control requirements associated with this batch were met, unless otherwise noted.

The condition of the samples analyzed was acceptable upon receipt per laboratory protocol unless otherwise noted on this report. Results represent the analysis of samples submitted by the client. Sample location, description, area, etc., was provided by the client. Results reported above in mg/cm³ are calculated based on area supplied by client. This report shall not be reproduced except in full, without the written consent of Environmental Hazards Services, L.L.C.

ELLAP Accreditation through AIHA LAP, LLC (100420), NY ELAP #11714.

LEGEND	Pb= lead	ug = microgram	ppm = parts per million
	ug/g = micrograms per gram	Wt. = weight	

County of Nevada
Information & General Services Department
Purchasing Division



Invitation for Bid

For

Brunswick Commons Resource Center Project

Date issued: Friday, December 8, 2023

Bids Due: 2:00 PM, Wednesday, January 10, 2024

In person to:
950 Maidu Ave.
Nevada City, CA 95959

The County will conduct this public bid opening through the following on-line site:

Pre-Bid Site Visit (recommended)

9:30AM, Thursday, December 14, 2023

at:

1105 Sutton Way, Grass Valley, CA 95945

The County will conduct the Pre-Bid meeting in person. In addition, the County will host a virtual Pre-Bid meeting for those unable to attend in person. A link to the virtual meeting is provided in the Bid documents

BIDDING DOCUMENTS, SPECIFICATIONS
AND CONTRACT DOCUMENTS
(Standard Public Works Contract)

CONTRACT TIME LINE

1. BIDS DUE: **2:00 PM, Wednesday, January 10, 2024**
(See page 3 of Invitation for Bid)
2. BID OPENING: **2:30 PM, Wednesday, January 10, 2024**
(See page 3 of Invitation for Bid)
3. BIDS TO REMAIN OPEN FOR **60** DAYS FROM DATE OF OPENING OF BIDS (See paragraph 21 of Instructions to Bidders)
4. NOTICE OF AWARD DUE WITHIN **30** DAYS OF OPENING OF BIDS (See paragraph 23 of Instructions to Bidders and same as 3 above)
5. BID BONDS OF UNSUCCESSFUL BIDDERS TO BE RETURNED WITHIN **10** DAYS OF AWARD BY COUNTY (See paragraph 18 of Instructions to Bidders)
6. CONTRACT SIGNING AND BONDS DUE WITHIN **5** DAYS OF NOTICE OF AWARD (See paragraph 24 and 26 of Instructions to Bidders)
7. NOTICE TO PROCEED WITH WORK DUE WITHIN **15** DAYS OF CONTRACT SIGNING (See paragraph 25 of Instructions to Bidders)
8. CONSTRUCTION MUST BEGIN WITHIN **10** DAYS AFTER MAILING OF NOTICE TO PROCEED (See paragraph 2 of Contract)
9. CONTRACTOR MUST GIVE 72 HOURS WRITTEN NOTICE OF DATE WORK WILL COMMENCE.
10. PRECONSTRUCTION CONFERENCE WITHIN **5** DAYS OF NOTICE TO PROCEED (See Article III of Contract)
11. SCHEDULES AND BREAKDOWN OF PHASES OF CONSTRUCTION DUE IN **7** DAYS AFTER RECEIPT OF NOTICE TO PROCEED (See Article III of Contract)
12. WORK MUST BE COMPLETED WITHIN **180** DAYS OF MAILING OF THE NOTICE TO PROCEED (See Article III of Contract)

INVITATION FOR BID

FOR: **Brunswick Commons Resource Center Project**

LOCATED AT: **1105 Sutton Way, Grass Valley, CA 95945**

Sealed bids will be received at the office of the:

Purchasing Division
Suite 129
County of Nevada
950 Maidu Ave.
Nevada City, California 95959

Submittals are to be received by mail, or if hand delivered, must be placed in a sealed envelope with the name of the project clearly printed on the front of the envelope and should be delivered to the Purchasing Division in the Eric Rood Administrative Center. All bids will be dated and time-stamped once received by the County representative.

Until **2:00 PM** local time on **Wednesday, January 10, 2024** for the above referenced project.

Bids received after said time will not be accepted and will be returned unopened.

At said place and time, and promptly thereafter, all bids that have been properly submitted will be publicly opened and read aloud. All interested parties are invited to attend.

The County will conduct this public bid opening through the following on-line site: Nevada County is inviting you to a scheduled TEAMS meeting at 2:30 PM, Wednesday, January 10, 2024

The work to be performed includes the following:

Tenant improvement of approximately 3,000 square feet, of the 6,076 square foot first floor, for office and a homeless resource center. Site improvements including ADA path of travel, parking and trash enclosure.

ENCLOSURE

Bids shall be: **Lump Sum.**

Bids must be for all of the work described herein unless the bid form specifically indicates a bid item is optional.

Bids shall be: **Lump Sum.** Bids must be for all work described herein unless the bid form specifically indicates a bid item is optional. Plans, specifications, proposal forms, project manuals and all documents relating to this project can only be obtained at the office or website

www.mynevadacounty.com/purchasing under *Current Requests for Bids and Proposals*

Vendors must register with the County in order to be notified of addenda and other notices.

To register, please go to: <https://www.publicpurchase.com/gems/register/vendor/register>.

The County will not be providing printed copies of the plans to bidders for this project.

Contractor will be required to possess a **B** contractor's license at the time the bid is submitted.

A pre-bid walk-through will be held beginning at 9:30AM, Thursday, December 14, 2023 at the project site at 1105 Sutton Way, Grass Valley, CA 95945

The County will conduct the Pre-Bid meeting in person however. In addition, the County will host a virtual Pre-Bid meeting for those unable to attend in person. A link to the virtual meeting is provided below:

Bids will be accepted from bidders who did not attend the pre-bid conference, but bidders will be charged with all of the information disseminated at the pre-bid conference as if they had been present.

Questions regarding the Work or the contract Documents shall be submitted online on Public Purchase due before 12:00PM, Wednesday, December 20, 2023.

Bids shall be received by **2:00 PM, Wednesday, January 10, 2024**. For all bids over \$25,000, each bidder must submit a cashier's check, certified check or a bidder's bond in an amount equal to 10% of the total amount of the bid.

The bidder to whom a contract is awarded will be required to furnish a performance bond and a labor and materials bond guaranteeing faithful performance and payment of all debts related to this contract.

The County of Nevada, in accordance with Title VI of the Civil Rights Act of 1964 (78 Stat. 252) and the regulations of the Department of Commerce (15 C.F.R., Part 8), issued pursuant to such Act, hereby notifies all bidders that it will affirmatively ensure that in any contract entered into pursuant to this advertisement, minority business enterprises will be afforded full opportunity to submit bids in response to this invitation and will not be discriminated against on the grounds of race, color, or national origin in consideration for an award.

This is a public works project, subject to the prevailing wage requirements of the California Labor Code. Copies of the prevailing rate of per diem wages are available at the California Department of Industrial Relations web site www.dir.ca.gov/DLSR/PWD/. Contractor shall not pay less than the prevailing rate of wages. No contractor or subcontractor may be listed on a bid proposal for a public works project (submitted on or after March 1, 2015), unless registered with the Department of Industrial Relations pursuant to Labor Code section 1725.5 [with limited exceptions from this requirement for bid purposes only under Labor Code section 1771.1(a)]. No contractor or subcontractor may be awarded a contract for public work on a public works project (awarded on or after April 1, 2015) unless registered with the Department of Industrial Relations pursuant to Labor Code section 1725.5. This project is subject to compliance monitoring and enforcement by the Department of Industrial Relations.

No bid will be considered unless it is made on a form furnished by the County of Nevada and is made in accordance with the provisions of the proposal requirements and conditions set forth in the contract documents.

The County of Nevada reserves the right to reject any or all bids.

DATED: _____

COUNTY OF NEVADA
STATE OF CALIFORNIA

By _____
Chairman, Board of Supervisors or
Purchasing Agent

INSTRUCTIONS TO BIDDERS

FOR: **Brunswick Commons Resource Center Project**

LOCATED AT: **1105 Sutton Way, Grass Vally CA 95945**

1. DEFINITIONS

Bidder: One who submits a bid directly to County as distinct from a sub-bidder who submits a bid to a bidder.

Successful Bidder: The lowest, qualified, responsive, responsible bidder to whom County makes an award.

Bidding Documents:

- Invitation for Bid
- Instruction to Bidders
- Bid Form
- Bidders Bond or other security
- Experience Statement
- Subcontractor Listing
- Bidder's Representations
- Proposed Contract Documents
- Any and all Addenda

2. COPIES OF BIDDING DOCUMENTS

Complete copies of the bid documents and specifications for use in preparing bids may be obtained in accordance with the Invitation for Bid. Bid documents are also available electronically and can be downloaded from www.mynevadacounty.com/purchasing under the Requests for Bids and Proposals section Requests For Proposal section. Addenda will also be posted to this location. Vendors must register with the County in order to be notified of addendums and other notices. To register, please go to: <https://www.publicpurchase.com/gems/register/vendor/register>.

Partial sets of bidding documents will not be issued. Complete sets of bidding documents shall be used in preparing bids. County assumes no responsibility for errors or misinterpretations resulting from the use of incomplete sets of bidding documents. If bidder believes its set of bidding documents is incomplete, it shall be the responsibility of bidder to contact County to confirm that Bidder has a complete set.

County, in making copies of bidding documents available on the above terms, does so only for the purpose of obtaining bids on the work and does not confer a license or grant for any other use.

3. QUALIFICATIONS OF BIDDERS

Each bidder must be prepared to submit, within five days of County's request, written evidence of bidder's qualifications to perform the work. Bidders may be required to submit evidence that they have a practical knowledge of the particular work bid upon, and that they have the financial resources to complete the proposed work. In determining the bidder's qualifications, the following factors will be considered: work previously completed by the bidder and whether the bidder (a) maintains a permanent place of business, (b) has adequate plant and equipment to do the work properly and expeditiously, (c) has the financial resources to meet all obligations incident to the work, and (d) has appropriate technical experience. Each bidder may be required to show that he or she has handled former work so that no just claims are pending

against such work. No bid will be accepted from a bidder who is engaged on any work which would impair his or her ability to perform or finance this work.

Each bidder must hold a current valid contractor's license at the time of bidding or the bid will be rejected.

4. INSPECTION OF SITE OF WORK

Bidders are required to inspect the site of the work in order to satisfy themselves, by personal examination or by such other means as they may prefer, of the location of the proposed work and as to the actual conditions of and at the site of work. If, during the course of the examination, bidder finds facts or conditions which appear confusing to bidder, bidder shall apply to County for additional information and explanation before submitting the bid. However, no such supplemental information so requested or furnished shall vary the terms of the specifications or the Contractor's sole responsibility to satisfy himself or herself as to the conditions of the work to be performed, unless an addendum has been issued.

The submission of a bid by the bidder shall constitute the acknowledgment that, if awarded the contract, bidder has relied and is relying on bidder's examination of (a) the site of the work, (b) the access to the site, and (c) all other data, matters, and things requisite to the fulfillment of the work and on bidder's own knowledge of existing conditions on and in the vicinity of the site of the work to be constructed under the contract, and not on any representation or warranty of County. No claim for additional compensation will be allowed which is based upon a lack of knowledge of the above items.

Where technical reports or data have been utilized in the preparation of the contract documents, bidder may rely upon the accuracy of the technical data contained in such reports but not upon the interpretations or opinions contained therein for the completeness thereof for the purpose of bidding or construction.

Where plans and specifications contain drawings of physical conditions in or relating to existing surface conditions, including underground facilities, which are at or contiguous to the site, bidder may rely upon the accuracy of the data contained in such drawings but not upon the completeness thereof for the purposes of bidding or construction. If a mass diagram has been prepared for a project, it is for design purposes only. If it is made available to bidders, County assumes no responsibility whatever for the information contained therein and makes no guarantees with respect to reliance thereon.

Before submitting a bid, each bidder will, at bidder's own expense, make or obtain any additional examinations, investigations, explorations, tests and studies and obtain any additional information and data which pertain to the physical conditions (surface, subsurface and underground facilities) at or contiguous to the site or otherwise which may affect cost, progress, performance or furnishing of the work and which bidder deems necessary to determine its bid for performing and furnishing the work in accordance with the time, price and other terms and conditions of the contract documents.

On request in advance, County will provide each bidder access to the site to conduct such explorations and tests as each bidder deems necessary for submission of a bid. Bidder shall fill all holes, clean up and restore the site to its former condition upon completion of such explorations.

The lands upon which the work is to be performed, rights-of-way and easements for access thereto and other lands designated for use by Contractor in performing the work are identified in the contract documents. All additional lands and access thereto required for temporary construction facilities or storage of materials and equipment are to be provided by Contractor. Easements for permanent structures or permanent changes in existing structures are to be obtained and paid for by County unless otherwise provided in the contract documents.

5. EXAMINATION OF CONTRACT DOCUMENTS

The contract documents shall consist of the following:

1. Invitation for Bid
2. Instruction to Bidders
3. Contractor's Bid (including documentation accompanying the Bid and any post-bid documentation submitted prior to the Notice of Award)
4. Contract
5. Addenda which pertain to the Contract
6. The Bonds or other security
7. Any supplementary conditions or any and all written agreements amending or extending the work, time or price contemplated
8. The Plans and Specifications and Drawings as identified in the Contract
9. Certificates of Insurance
10. Other: _____

Each bidder shall thoroughly examine and be familiar with legal and procedural documents, general conditions, specifications, drawings and addenda (if any). The submission of a bid shall constitute an acknowledgment upon which County may rely that the bidder has thoroughly examined and is familiar with the contract documents. The failure or neglect of a bidder to receive or examine any of the contract documents shall in no way relieve that bidder from any obligation with respect to that bidder's bid or to the contract. No claim for additional compensation will be allowed which is based upon a lack of knowledge of any contract documents.

6. INTERPRETATION OF CONTRACT DOCUMENTS

No oral representations or interpretations will be made to any bidder as to the meaning of the contract documents. Any ambiguities, inconsistencies in the plans and specifications or other contract documents, or problems which are visible by an inspection of the site or review of the contract documents shall be resolved prior to bidding. Request for an interpretation shall be made in writing and delivered to County at least 10 days before the time announced for opening the proposals. Interpretations by County will be in the form of an addendum to the contract documents and, when issued, will be sent as promptly as is practical to all parties to whom the bid documents have been issued. All such addenda shall become part of the contract. County reserves the right to amend any contract language which it determines is ambiguous prior to award of the bid.

7. ADDENDA

Each bid shall include specific acknowledgment, in the space provided, of receipt of all addenda issued during the bidding period. Failure to so acknowledge will result in the bid being rejected as not responsive. The Contractor is responsible for verifying that all addenda have been received and for obtaining all addenda prior to submitting bids for the work.

Only questions answered by formal written addenda will be binding. Oral and other interpretations or clarifications will be without legal effect.

Addenda may also be issued to modify the bidding documents as deemed advisable by County.

Addenda will be mailed or delivered to all parties recorded as having received the bidding documents. No addenda will be issued later than four days prior to the date for receipt of bids except an addendum, if necessary, postponing the date for receipt of bids or withdrawing the request for bids.

8. BIDS

Bids shall be made on the blank forms prepared by County and included herein. Bidders may extract these pages from the book of specifications or submit the entire book. All bids shall give prices, both in writing and in figures, and shall be signed by the bidder or bidder's authorized representative with bidder's address and shall provide all other information requested on the bid form. If the bid is made by an individual, his or her name, signature and post office address must be shown; if made by a firm or partnership, the name and post office address of the firm or partnership must be shown; if made by a corporation, the bid shall show the name of the state under the laws of which the corporation is chartered, the name and post office address of the corporation, and the title of the person who signs on behalf of the corporation.

9. SUBMISSION OF BIDS

Bids shall be submitted at the time and place indicated in the Invitation for Bid and shall be included in a sealed envelope addressed to the Nevada County Purchasing Division. If mailed, the bids shall be addressed to:

Submit Bids to: US Mail, Fed Ex, or UPS, etc. to:	Hand Deliver to:
Nevada County Purchasing Division	Nevada County Purchasing Division
Eric Rood Administrative Center	Eric Rood Administrative Center
P.O. Box 59902	950 Maidu Avenue Suite 129
950 Maidu Avenue Suite 129	Nevada City, CA 95959
Nevada City, CA 95959-7902	

The bid shall be identified on the outside with the bidder's name, license number and address and with the **Project Title "Brunswick Commons Resource Center Project."**

Each bid shall be accompanied by the bid security if bid over \$25,000 and other required documents.

If the bid is sent by mail, the sealed envelope shall be enclosed in a separate mailing envelope with the notation "BID ENCLOSED" with the **Project Title "Brunswick Commons Resource Center Project"** on the face thereof.

Bids shall be deposited at the designated location prior to the time and date for receipt of bids indicated in the Invitation for Bid, or the modified time and date indicated by addendum. Bids received after the time and date for receipt of bids will be returned unopened. Bidder shall assume full responsibility for timely delivery at the location designated for receipt of bids.

Oral, telephone, or telegraph bids are invalid and will not receive consideration. No bidder may submit more than one bid. Multiple bids under different names will not be accepted from one firm or association.

10. PRE-BID CONFERENCE OR WALK-THROUGH

A pre-bid conference or walk-through will be held at **9:30AM, Thursday, December 14, 2023**, at the project site at **1105 Sutton Way, Grass Valley CA 95945**.

The representatives of County, any consultants and/or Project Engineer will be present to answer questions. Any questions which, in the opinion of County, cannot be answered by direct reference to the bidding documents will be answered by formal written addenda as outlined above.

The pre-bid conference or walk-through may include a tour of the site of the work conducted by representatives of County. All interested parties are invited to attend.

11. BID PRICE

The bid price shall include everything necessary for the completion of construction and fulfillment of the contract including, but not limited to, furnishing all materials, equipment, tools, plant and other facilities and all management, superintendence, labor and services, except as may be provided otherwise in the contract documents.

In the event of a difference between the price quoted in words and a price quoted in figures for the same quotation, the words shall be considered the amount bid. Discrepancies between the indicated sum or total of figures and the correct sum or total will be resolved in favor of the correct sum or total.

12. BASIS OF BIDS

The bidder shall submit both a lump sum price and prices for all unit cost items and alternatives shown on the bid form. Failure to comply may be cause for rejection.

Where specific quantities are given they are approximate only, being given as a basis for the comparison of bids, and the County of Nevada does not, expressly or by implication, warrant that the actual amount of work will correspond therewith, but reserves the right to increase or decrease the amount of any class or portion of the work or to omit portions of the work as may be deemed necessary or advisable by County. The amount of the bid for comparison purposes will be the total of all items. The total of unit basis items will be determined by extension of the item price bid on the basis of the estimated quantity set forth for the item.

The bidder shall set forth for each item of work, in clearly legible figures, an item price and a total for the item in the respective spaces provided for this purpose. In the case of unit basis items, the amount set forth under the "Total" column shall be the extension of the item price bid on the basis of the estimated quantity for the item.

In case of discrepancy between the item price and the total set forth for the item, the item price shall prevail; however, if the amount set forth as an item price is ambiguous, unintelligible or uncertain for any cause, or is omitted, or in the case of unit basis items is the same amount as the entry in the "Total" column, then the amount set forth in the "Total" column for the item shall prevail in accordance with the following:

- a. As to unit basis items, the amount set forth in the "Total" column shall be divided by the estimated quantity for the item and the price thus obtained shall be the item price.
- b. As to lump sum items, the amount set forth in the "Total" column shall be the item price.

In accordance with the provision of Section 6707 of the State Labor Code, each bidder shall list, in any bid item calling for trenching of 5 feet or more in depth, the amount contained in the proposal for adequate trench and excavation sheeting, shoring, and bracing or equivalent method for the protection of life and limb which shall conform to applicable Safety Orders.

13. TAXES

Bid prices shall include allowance for all federal, state and local taxes.

14. CONTRACT TIME

The date by which the work is to be completed (the contract time) is set forth in the contract documents.

15. SUBSTITUTE MATERIAL AND EQUIPMENT

The contract, if awarded, will be on the basis of material and equipment described in the drawings or specified in the specifications without consideration of possible substitute or "co-equal" items. Whenever it is indicated in the drawings or specified in the specifications that a substitute or "co-equal" item of material or equipment may be furnished or used by Contractor if acceptable to County, application for such acceptance will not be considered by County until after the effective date of the contract unless an addendum is issued to all bidders authorizing the use of a specified substitute. The procedure for submittal of any such application by Contractor and consideration by County is set forth in the contract documents.

16. LIST OF SUBCONTRACTORS

Each bid shall have listed on the form provided herewith the name and address of each subcontractor to whom the bidder proposes to sublet portions of the work in excess of one-half of one percent of the total amount of the bid or, in the case of bids for construction of streets or highways, including bridges, in excess of one-half of one percent of the Contractor's total bid or \$10,000, whichever is greater, per Public Contracts Code Section 4104. For the purpose of this paragraph, a subcontractor is defined as one who contracts with the Contractor to furnish materials and labor, or labor only for the performance of work at the site of the work.

County has the right to review the suitability and qualifications of any subcontractor or supplier proposed by the Contractor. As part of this review County may request an experience statement with pertinent information as to similar projects and other evidence of qualification for each such subcontractor, person and organization. If County, after due investigation, has reasonable objection to any proposed subcontractor, County may, before giving the notice of award, request the apparent successful bidder to submit an acceptable substitute without an increase in bid price. If the apparent successful bidder does not make such substitution, the contract shall not be awarded to such bidder, but Contractor's failure to make such substitution will not constitute grounds for sacrificing the bid security. Any subcontractor, other person or organization so listed and to whom County does not make written objection prior to the giving of the notice of award will be deemed acceptable to County subject to revocation of such acceptance after the effective date of the agreement as provided in the contract documents.

No Contractor shall be required to employ any subcontractor, other person or organization against whom Contractor has reasonable objection.

The Contractor may not change any subcontractor listed on its bid without written approval from County after a determination that the requirements of Public Contracts Code Section 4107 have been met.

17. BID GUARANTY (BID BOND)

Bid Guaranty (Bid Bond) is required on all bids over \$25,000. The bid shall be accompanied by a bid guaranty bond (bid bond) duly completed on the form provided herewith or a form which is substantially similar, by a guaranty company authorized to carry on business in the State of California, for payment to County in the sum of at least 10 percent of the total amount of the bid, or alternatively by a certified or cashier's check, payable to County in the sum of at least 10 percent of the total amount of the bid. A bid bond form which provides further payment of attorney's fees or which contains a termination date will not be considered to be "substantially similar". The amount payable to County under the guaranty bond, or the certified or cashier's check and the amount thereof, as the case may be, shall be forfeited to County as liquidated damages in case of a failure or neglect of the bidder to furnish, execute and deliver to County the required performance and payment bonds, evidence of insurance, and to enter into, execute and deliver to County the contract on the form provided herewith, within 5 days after being notified in writing by County that the award has been made and the agreement is ready for execution.

All bonds shall have a power of attorney authorizing the signature of the person authorized to sign on behalf of the Surety attached to the bond. The power of attorney signature and the principal's signature shall each (both) be notarized.

The bid bond shall name County as beneficiary and shall specify that the bond is valid for the bid opening of this project as scheduled in the Invitation for Bid.

18. RETURN OF BID GUARANTEES

Within 10 days after the bids are awarded, County will return the bid guarantees (other than bid bonds) accompanying the bids for bids not considered in making the award. All other bid guaranties will be held until the contract has been fully executed, after which they will be returned to the respective bidders whose bids they accompany.

19. MODIFICATION OR WITHDRAWAL OF BIDS

Bids submitted early may be modified or withdrawn by notice to the party receiving bids at the place and prior to the time designated for receipt of bids. Such notice shall be in writing over the signature of the bidder or be by telegram; if by telegram, written confirmation over the signature of bidder must have been mailed and postmarked on or before the date and time set for receipt of bids; it shall be so worded as not to reveal the amount of original bid. Bids may also be modified or withdrawn in person by the bidder or an authorized representative provided bidder can prove bidder's identity and authority. Withdrawn bids may be resubmitted up to the time designated for the receipt of bids provided that they are then fully in conformance with these instructions to bidders.

If, within 24 hours after bids are opened, any bidder files a duly signed written notice with County and promptly thereafter demonstrates to the reasonable satisfaction of County that there was a material and substantial mistake in the preparation of the bid, that bidder may withdraw his or her bid and the bid security will be returned. Thereafter, that bidder will be disqualified from further bidding on the work.

20. OPENING OF BIDS

Bids will be opened publicly and read aloud. An abstract of the amounts of the base bids and major alternates (if any) will be made available after the opening of bids.

21. BIDS TO REMAIN OPEN

All bids shall remain open and subject to acceptance for a period of **60** days from the date of opening, but County may, in County's discretion, release any bid and return the bid security prior to that date.

22. POSTPONEMENT OF OPENING

County reserves the right to postpone the date and time for opening of bids at any time prior to the date and time announced in the advertisement.

23. AWARD OF CONTRACT

The award of the contract, if awarded, will be made to the lowest responsive, responsible bidder whose bid complies with all the requirements stated herein. The lowest bidder will be the bidder whose total bid price for all phases of work is lowest. The County will determine after receipt of bids which phase or phases will be included in the contract based on the bid amounts for each respective phase as submitted by the lowest bidder. Within **60** days after the time of opening the bids, County will act either to accept a proposal or to reject all proposals. The acceptance of a proposal will be evidenced by a notice of award of contract in writing, delivered in person or by mail to the bidder whose proposal is accepted. No other act of County shall constitute acceptance of a bid. The award of contract shall obligate the bidder whose bid is accepted

to furnish a performance bond, payment bond and evidences of insurance (certificates of insurance and endorsements specified in the contract) and execute the agreement set forth in the contract documents.

County reserves the right to reject any and all bids and to waive any and all formalities, and the right to disregard all nonconforming, non-responsive, or conditional bids. County reserves the right to reject the bid of any bidder if County believes that it would not be in the best interest of the project to make an award to that bidder, whether because the bid is not responsive or the bidder is unqualified or of doubtful financial ability or fails to meet any other pertinent standard or criteria established by County. County reserves the right to reject any bids which omit a bid on any one or more items on which bids are required; any bids which omit unit prices if unit prices are required; any bids in which unit prices are unbalanced in the opinion of County; any bid accompanied by insufficient or irregular bid security; and any bids from bidders who have previously failed to perform properly or to complete on time contracts of any nature.

It is County's intent to accept alternates (if any are accepted) in the order in which they are listed in the bid form, but County may accept them in any order or combination.

County may consider the qualifications and experience of subcontractors and other persons and organizations (including those who are to furnish the principal items of material or equipment) proposed for those portions of the work as to which the identity of subcontractors and other persons and organizations must be submitted as provided herein. Operating costs, maintenance considerations, performance data and guarantees of materials and equipment may also be considered by County.

If there is reason to believe that collusion exists among the bidders, none of the bids of the participants in such collusion will be considered, and County may likewise elect to reject all bids received.

County may conduct such investigations as County deems necessary to assist in the evaluation of any bid and to establish the responsibility, qualifications and financial ability of the bidders, proposed subcontractors and other persons and organizations to do the work in accordance with the contract documents to County's satisfaction within the prescribed time. County reserves the right to reject the bid of any bidder who does not pass any such evaluation to County's satisfaction.

If the contract is to be awarded, it will be awarded to the lowest bidder whose evaluation by County indicates to County that the award will be in the best interests of the project.

24. SIGNING OF AGREEMENT

When County gives a Notice of Award to the successful bidder, it will be accompanied by unsigned counterparts of the agreement and all other contract documents.

Three (3) copies of the contract documents will be prepared by County. All copies will be submitted to Contractor, and Contractor shall execute the contract, insert executed copies of the required bonds and power of attorney, and submit all copies to County within five **(5)** days. The date of execution of the contract shall be left blank for filling in by County.

25. NOTICE TO PROCEED

County shall give the successful bidder written notice to proceed with the work within **7** days of the execution of the contract. Notwithstanding any other provision of the contract, County shall not be obligated to accept or to pay for any work furnished by the Contractor prior to delivery of notice to proceed whether or not County has knowledge of the furnishing of such work.

26. PERFORMANCE AND OTHER BONDS

The contract documents set forth County's requirements as to performance and other bonds. When the successful bidder delivers the executed contract to County, it shall be accompanied by the required contract security. The bonds shall be provided on County's forms or on forms which are substantially similar. Notwithstanding any language contained in the bonds, County shall not be liable for attorney's fees either

for the enforcement of the bond or for any other action under this Contract. Bonds shall not contain any date of termination.

27. CONTRACTUAL RESTRICTIONS

No official of County who is authorized in such capacity and on behalf of County to negotiate, make, accept or approve, or to take part in negotiating, making, accepting, or approving any architectural, engineering, inspecting, construction or material supply contract or any subcontract in connection with the construction of the project, shall become directly or indirectly interested personally in this contract or in any part thereof. No officer, employee, architect, attorney, engineer, or inspector of or for County who is authorized in such capacity and on behalf of County who is in any legislative, executive, supervisory, or other similar function in connection with the construction of the project, shall become directly or indirectly interested personally in this contract or in any part thereof, any material supply contract, subcontract, insurance contract, or any other contract pertaining to the project.

28. POSTING SECURITY IN LIEU OF RETENTION

The Contractor may elect to receive 100% of payments due under this contract from time to time, without retention of any portion of the payment by the public agency, by depositing securities of equivalent value with County in accordance with the provisions of Section 22300 of the California Public Contract Code; except that no such substitution shall be allowed where federal money is funding the project and federal regulations or policies would prohibit such substitution of securities for the retention. Securities eligible for investment shall include those listed in Section 16430 of the California Government Code, or bank or savings and loan certificates of deposits. Such securities, if deposited by the bidder, shall be valued by County whose decision on the valuation of the securities shall be final. The bidder shall be the beneficial owner of any securities substituted for money withheld and shall receive any interest thereon.

29. LIQUIDATED DAMAGES

The County is authorized by Government Code Section 53069.85 to assess liquidated damages for delay. County refers bidders to the Contract for review of the liquidated damages provision to be included in this Contract.

CHECKLIST OF DOCUMENTS ENCLOSED BY BIDDER

Bidder shall acknowledge that he or she has enclosed all required Bidding Documents listed herein by signing his or her initials in "Bidder" column, after each item.

DOCUMENT	SIGNATURES	
	BIDDER	COUNTY REP.
1. BID FORM (signed)		
2. ACKNOWLEDGMENT OF ADDENDA		
3. BID SECURITY: Bid Bond for bids over \$25,000 (must be signed by corporate surety); or Cashier's Check; or Certified Check; or Cash		
4. EXPERIENCE STATEMENT FORM		
5. SUBCONTRACTOR LISTING (signed)		
6. BIDDER'S REPRESENTATIONS: (BIDDER'S QUALIFICATIONS, NONCOLLUSION DECLARATION)		

BID FORM

(Nevada County Standard Form Bid Document)

BID TO THE COUNTY OF NEVADA FOR: **Brunswick Commons Resource Center Project**

Name of Bidder _____

The work to be done and referred to herein is in Nevada County, State of California, and shall be constructed in accordance with the Plans, Specifications (including the payment of not less than the wages rates set forth therein) and the Contract annexed hereto.

The work to be done is shown upon project documents entitled: **Brunswick Commons Resource Center Project**. The undersigned, as bidder, declares that the only persons or parties interested in this bid as principals are those named herein; that this bid is made without collusion with any other person, firm, or corporation, and in submitting this bid, the undersigned bidder agrees that he or she has carefully examined the location of the proposed work, the annexed proposed form of contract, and the plans therein referred to and all other documents listed or incorporated in the bidding documents and contract documents; and bidder proposes, and agrees if this bid is accepted, that bidder will contract with the County of Nevada in the form of the copy of the contract annexed hereto, to provide all necessary machinery, tools, apparatus, and other means of construction, and to do all the work and furnish all the materials specified in the contract, in the manner and time therein prescribed, and according to the requirements of County as therein set forth, and that bidder will take in full payment therefor the following:

Item No.	Item	Unit of Measure	Total
1.	Brunswick Commons Resource Center Project	Lump Sum	

Total of Bid (in figures): _____

Total of Bid (in words): _____

The undersigned bidder agrees to furnish the required bonds or other security and to enter into a contract within the time specified in the Instructions to Bidders, and further agrees to complete all work covered by the bid, in accordance with all requirements of the contract.

Receipt of copies of the following addenda is hereby acknowledged.

<u>Addendum No.</u>	<u>Bidder's Signature</u>	<u>Date Acknowledged</u>
_____	_____	_____
_____	_____	_____

All addenda received have been considered in preparation of this bid.

Enclosed herewith are the Bid Form, Bid Bond or other security, Experience Statement, Subcontractor Listing and Bidder's Representations form.

In submitting this bid it is understood that the right is reserved by County to reject any and all bids, and it is understood that this bid may not be withdrawn during the period set forth in the Instructions to Bidders.

Envelopes containing bids must be marked as required by the Instructions to Bidders.

County reserves the right to reject any and all bids and to waive any irregularities in bids.

The amount of the bid for comparison purposes will be the total of all items. The total of unit basis items will be determined by extension of the item price bid on the basis of the estimated quantity set forth for the item.

Prices bid shall include overhead, profit and all applicable taxes.

By submission of this bid, each bidder certifies, and in the case of a joint bid each party thereto certifies as to its own organization, that this bid has been arrived at independently, without consultation, communication, or agreement as to any matter relating to this bid with any other bidder or with any competitor.

A bid bond for bids over \$25,000 will accompany this bid in a sum of not less than ten percent (10%) of the total amount of the bid and shall be on a form approved by County or a form which is substantially similar, which is attached hereto.

If this bid shall be accepted and the undersigned shall fail to contract as aforesaid, and to give the performance bond and labor and material bond as required in the contract with a surety satisfactory to County within the number of days set forth in the Instructions to Bidders after receipt of notice that the contract has been awarded to the undersigned, County may, at its option, determine that the bidder has abandoned the contract and thereupon the award of the contract shall be null and void and the bidder and surety shall forfeit the security accompanying this bid to the County of Nevada.

Accompanying this bid is: Circle one: Bidder's Bond -- Cashier's Check -- Certified Check -- Cash

for \$ _____, an amount equal to ten percent (10%) of the total bid.

The names of individuals who are principals in any partnership, joint venture, business association or corporation in the foregoing bid are as follows:

Licensed in accordance with an act providing for the registration of contractors, License No. _____

DATED: _____
Authorized Signature of Bidder

PRINTED NAME OF AUTHORIZED REPRESENTATIVE: _____

BUSINESS ADDRESS: _____

PLACE OF RESIDENCE: _____

TELEPHONE NUMBER: _____

EMAIL ADDRESS: _____

CLASSIFICATION OF CONTRACTOR'S LICENSE: _____

EXPIRATION DATE OF CONTRACTOR'S LICENSE: _____

DIR# _____ FEDERAL TAX ID. NO.: _____

NOTE: If bidder is a corporation, the legal name of the corporation shall be set forth above together with the signature of the officer or officers authorized to sign contracts on behalf of the corporation; if bidder is

a co-partnership, the true name of the firm shall be set forth above together with the signature of the partner or partners authorized to sign contracts on behalf of the co-partnership; and if bidder is an individual, his or her signature shall be placed above. If a bidder is a joint venture, the documents must be signed by an authorized officer of each firm to the joint venture and shall include the California Contractor's License number of each partner to the joint venture. The signature of any attorney-in-fact must be notarized.

BIDDER'S BOND

STATE OF CALIFORNIA

COUNTY OF NEVADA

KNOW ALL PERSONS BY THESE PRESENT,

That we, _____ as principal, and _____ as surety, are held and firmly bound unto the County of Nevada in the sum of ten percent (10%) of the total amount of the bid of the principal above named, submitted by said principal to the County of Nevada for the work described below, for the payment of which sum in lawful money of the United States, well and truly to be made, to the County of Nevada, we bind ourselves, our heirs, executors, administrators, and successors, jointly and severally, firmly by these presents. In no case shall the liability of the surety hereunder exceed the sum of \$ _____.

The condition of this obligation is such that whereas the principal has submitted the above-mentioned bid to the County of Nevada, as aforesaid, for certain construction specifically described as follows, for which bids are to be opened at Nevada City, California on _____, 20__ for _____.

NOW, THEREFORE, if the aforesaid principal is awarded the contract, and within the time and manner required by the contract documents, after the prescribed forms are presented to him or her for signature, enters into a written Contract, in the prescribed form, in accordance with the bid, and files two bonds with the County of Nevada, one to guarantee faithful performance and the other to guarantee payment for labor and materials, as required by law, then this obligation shall be null and void; otherwise it shall be and remain in full force and effect.

Notice to Surety shall be provided at:

IN WITNESS WHEREOF, we have hereunto set our hands and seals on this _____ day of _____, A.D. 20__.

_____ Seal	_____ Seal
_____ Seal	_____ Seal
_____ Seal	_____ Seal
Principal	Surety

NOTE: Signature of Surety shall be notarized. Power of attorney for surety with corporate seal affixed must be attached.

APPROVED AS TO FORM
BY COUNTY COUNSEL

EXPERIENCE STATEMENT

The following outline is a record of the bidder's or subcontractor's recent experience in construction of a type similar in magnitude and character to that contemplated under this Contract. Additional numbered pages shall be attached to this page as required. Each page shall be headed "Experience Statement" and signed.

FAILURE TO COMPLETE WILL RESULT IN BID DISQUALIFICATION

1.) **PROJECT NAME:**

DATE:

INSPECTOR NAME

PHONE #

CONTRACT AMOUNT:

WORK PERFORMED:

2.) **PROJECT NAME:**

DATE:

INSPECTOR NAME

PHONE #

CONTRACT AMOUNT:

WORK PERFORMED:

3.) **PROJECT NAME:**

DATE:

INSPECTOR NAME

PHONE #

CONTRACT AMOUNT:

WORK PERFORMED:

4.) **PROJECT NAME:**

DATE:

INSPECTOR NAME

PHONE #

CONTRACT AMOUNT:

WORK PERFORMED:

Signature of Contractor

SUBCONTRACTOR LIST

Listed hereunder is the name, Contractor's license number, the address of place of business, and the category of the work on the Contract for each subcontractor who will perform work or labor or render service to the undersigned bidder in or about the construction of the work hereinabove described, in excess of one-half of one percent (0.5%) of the total bid, if the Contract for the said work is awarded to the undersigned.

(Attach additional sheet, if necessary, and note attachment on this page.)

Name of Subcontractor	Contractor's License #	DIR Registration Number	Location of Business	Category of Work To Be Performed	% of Total Work

Signature of Contractor/Bidder: _____

(THE BIDDER'S EXECUTION ON THE SIGNATURE PORTION OF THIS BID FORM SHALL ALSO CONSTITUTE AN ENDORSEMENT AND EXECUTION OF THOSE CERTIFICATIONS WHICH ARE A PART OF THIS BID)

BIDDER'S REPRESENTATIONS

I, the undersigned, declare as follows:

- 1. BIDDER'S QUALIFICATIONS: That neither I nor a company of which I am more than 50% owner have been disqualified from bidding, removed from a public works construction project or otherwise been prevented from bidding because of a violation of law or a safety regulation.

Further, I declare under penalty of perjury that neither I nor a company of which I am more than a 50% owner have had more than one final, unappealable finding of contempt of court by a Federal court within the immediately preceding two year period because of failure to comply with an order of the Federal court (Public Contract Code Section 10232), which orders the Contractor to comply with an order of the National Labor Relations Board.

Further, I declare under penalty of perjury that I have not been convicted by any court of any charge of fraud, bribery, collusion, conspiracy, or any other act in violation of state or federal antitrust law in connection with the bidding upon, award of, or performance of any public works contract.

- 2. WORKER'S COMPENSATION CERTIFICATION (LABOR CODE SECTION 1861): That I am aware of the provisions of Section 3700 of the Labor Code of the State of California, which requires every employer to be insured against liability for Worker's Compensation or to undertake self-insurance in accordance with the provisions of that Code, and I will comply with such provisions before commencing the performance of the work of this Contract.

- 3. NONCOLLUSION DECLARATION: I, the undersigned, declare that I am the _____ of _____ the party making the foregoing bid that the bid is not made in the interest of, or on behalf of, any undisclosed person, partnership, company, association, organization, or corporation; that the bid is genuine and not collusive or sham; that the bidder has not directly or indirectly induced or solicited any other bidder to put in a false or sham bid, and has not directly or indirectly colluded, conspired, connived, or agreed with any bidder or anyone else to put in a sham bid, or that anyone shall refrain from bidding; that the bidder has not in any manner, directly or indirectly, sought by agreement, communication, or conference with anyone to fix the bid price of the bidder or any other bidder, or to fix any overhead, profit, or cost element of the bid price, or of that of any other bidder, or to secure any advantage against the public body awarding the contract of anyone interested in the proposed contract; that all statements contained in the bid are true; and, further, that the bidder has not, directly or indirectly, submitted his or her bid price or any breakdown thereof, or the contents thereof, or divulged information or data relative thereto, or paid, and will not pay, any fee to any corporation, partnership, company, association, organization, bid depository, or to any member or agent thereof to effectuate a collusive or sham bid.

I declare under penalty of perjury under the laws of the State of California that the foregoing is true and correct.

DATED

: _____

BIDDER: _____

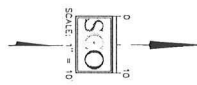
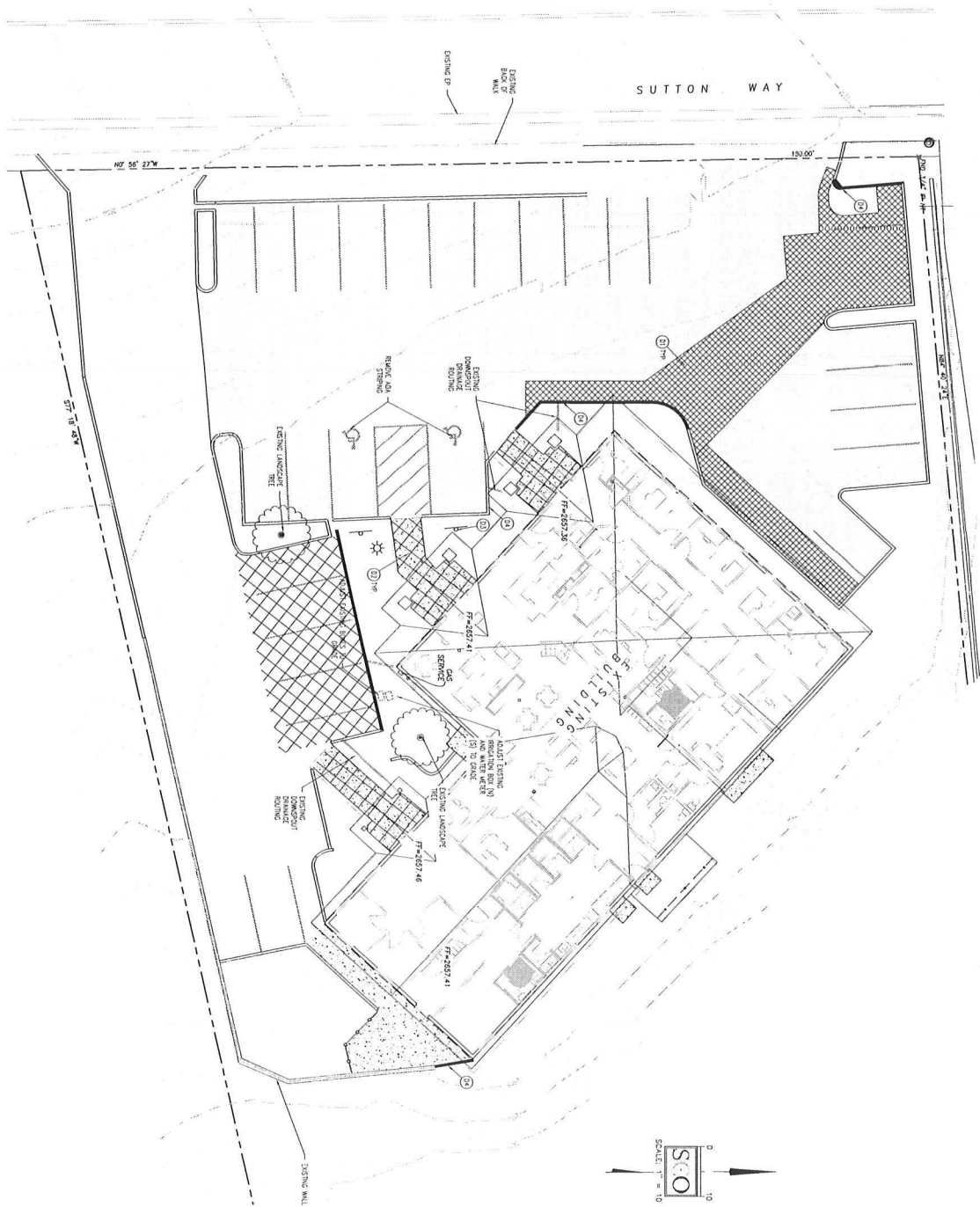

- LEGEND**
- CONCRETE TO BE REMOVED
 - ASPHALT TO BE REMOVED
 - EXISTING ASPHALT
 - EXISTING CONCRETE PAVEMENT
 - PROPERTY BOUNDARY
 - EXISTING MAJOR CONDUITS
 - EXISTING MINOR CONDUITS
 - EXISTING LANDSCAPE TREE
 - EXISTING LIGHT POLE

- DEMOLITION NOTES:**
- D1 SHED AND BUNKER ASHALL 1 SET DETAIL 1 SHEET C6
 - D2 REINFORCED CONCRETE PILE FOUNDATION
 - D3 REINFORCED CONCRETE MAIN FOUNDATION
 - D4 REINFORCED CONCRETE CURB

<p>SCO ENGINEERS & ARCHITECTS</p>	<p>CIVIL IMPROVEMENT PLANS SUTTON WAY WELLNESS CENTER EXISTING TOPOGRAPHY AND DEMOLITION PLAN</p>	<table border="1" style="width: 100%; border-collapse: collapse;"> <thead> <tr> <th>NO.</th> <th>REVISIONS</th> <th>DATE</th> <th>DESIGNED: JB</th> </tr> </thead> <tbody> <tr> <td> </td> <td> </td> <td> </td> <td> </td> </tr> <tr> <td> </td> <td> </td> <td> </td> <td> </td> </tr> <tr> <td> </td> <td> </td> <td> </td> <td> </td> </tr> <tr> <td> </td> <td> </td> <td> </td> <td> </td> </tr> </tbody> </table>	NO.	REVISIONS	DATE	DESIGNED: JB																	<p>DRAWN: HJD PROJ. NO: 202206 DATE: MAY, 2023 DWG: SEE DAY STAMP</p>
NO.	REVISIONS	DATE	DESIGNED: JB																				

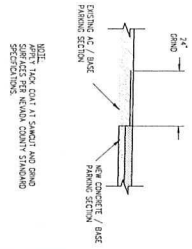

1 JOIN EXISTING ASPHALT
N1S

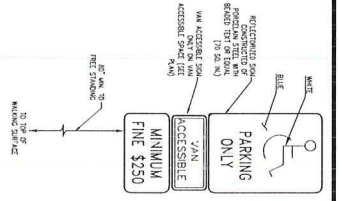

2 ADA PARKING SIGN
N1S

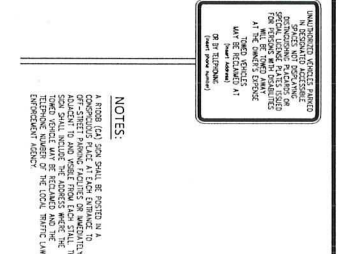

3 UNAUTHORIZED VEHICLE SIGN
N1S

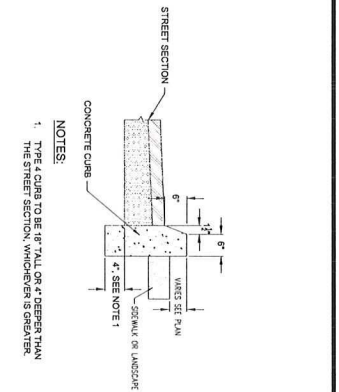

4 BARRIER CURB DETAIL
N1S

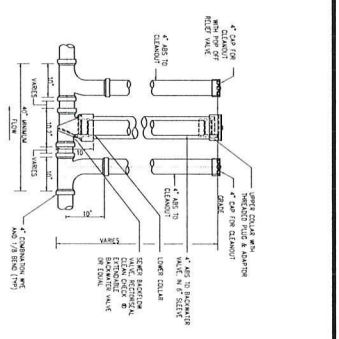

5 SEWER BACKFLOW VALVE AND CLEANOUT DETAIL
N1S

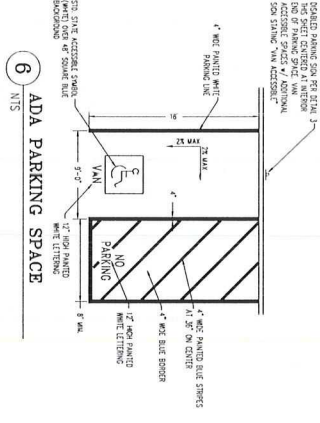

6 ADA PARKING SPACE
N1S

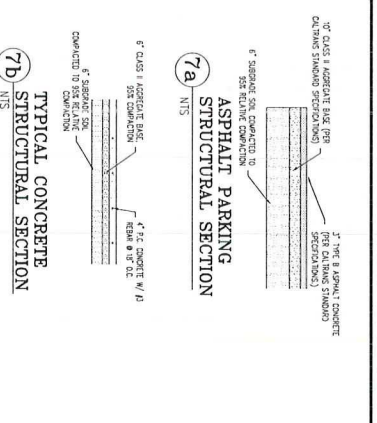

7a ASPHALT PARKING STRUCTURAL SECTION
N1S

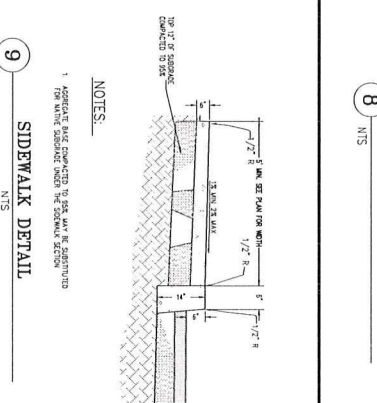

7b TYPICAL CONCRETE STRUCTURAL SECTION
N1S

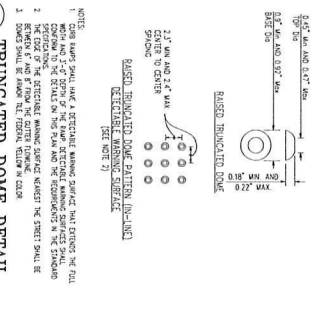

8 TRUNCATED DOME DETAIL
N1S

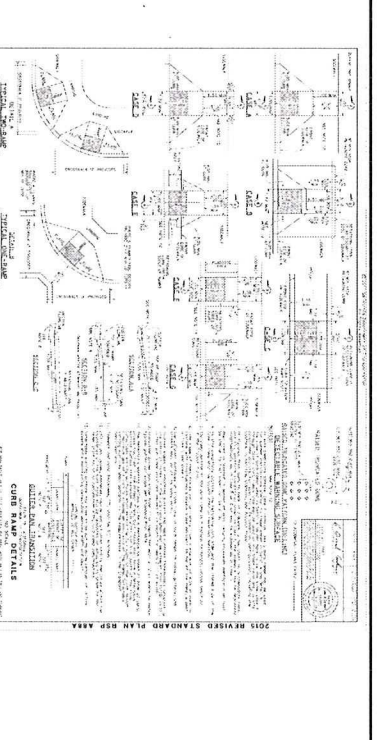

9 SIDEWALK DETAIL
N1S

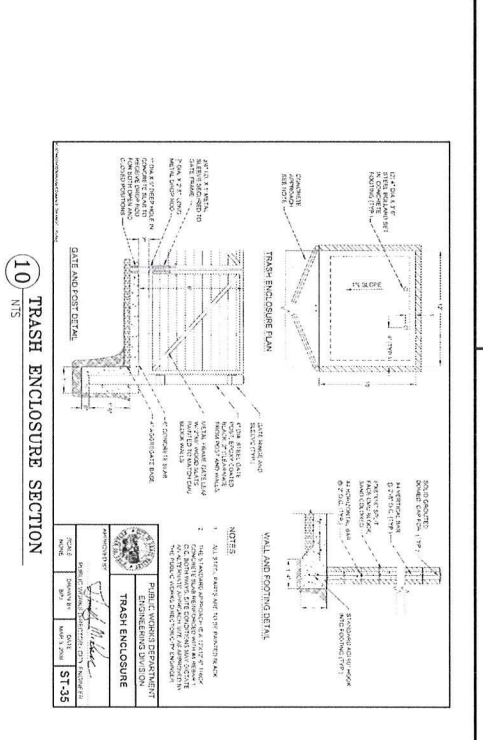

10 TRASH ENCLOSURE SECTION
N1S

51-1000-202306 - Sutton Way Wellness Center WSPA Revised 04/2023 (Improvement Plans) 04/2023 33 of 41 - AutoCAD Plot (General Documentation) 31

 <p>GRASS VALLEY SUTTON WAY WELLNESS CENTER IMPROVEMENT PLANS</p>	<p>CIVIL IMPROVEMENT PLANS SUTTON WAY WELLNESS CENTER DETAILS</p>		<p>DESIGNED: JB DRAWN: NJB PROJ. NO.: 202306 DATE: MAY, 2023 DWG: SEE DAY STAMP</p>
	<p>DATE PLOTTED: 05/02/2023 TIME PLOTTED: 10:58:44 AM PLOTTER: HP DesignJet 500</p>	<p>SCALE: AS SHOWN DATE: 05/02/2023 TIME: 10:58:44 AM</p>	<p>NO. REVISIONS</p>
	<p>DATE: 05/02/2023</p>	<p>SCALE: AS SHOWN</p>	<p>NO. REVISIONS</p>
	<p>DATE: 05/02/2023</p>	<p>SCALE: AS SHOWN</p>	<p>NO. REVISIONS</p>

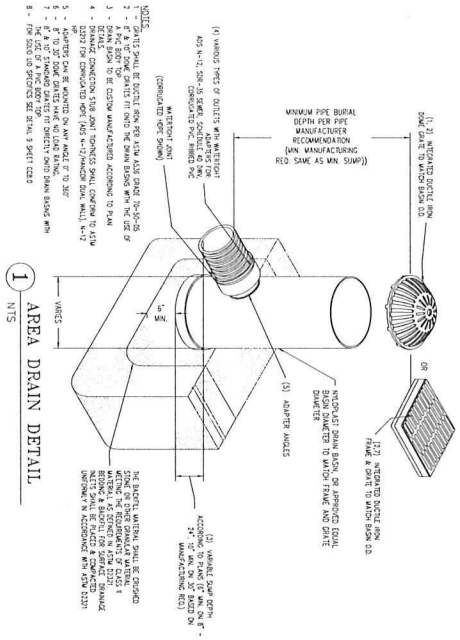

1 AREA DRAIN DETAIL
NTS

- NOTES:
1. 12" DIA. PIPE SHALL BE SET IN 4" MIN. CONC. BASE.
 2. 1/2" DIA. ADAPTER SHALL BE SET IN 4" MIN. CONC. BASE.
 3. 12" DIA. GRATE SHALL BE SET IN 4" MIN. CONC. BASE.
 4. 1/2" DIA. ADAPTER SHALL BE SET IN 4" MIN. CONC. BASE.
 5. 12" DIA. GRATE SHALL BE SET IN 4" MIN. CONC. BASE.
 6. 1/2" DIA. ADAPTER SHALL BE SET IN 4" MIN. CONC. BASE.
 7. 12" DIA. GRATE SHALL BE SET IN 4" MIN. CONC. BASE.
 8. 1/2" DIA. ADAPTER SHALL BE SET IN 4" MIN. CONC. BASE.

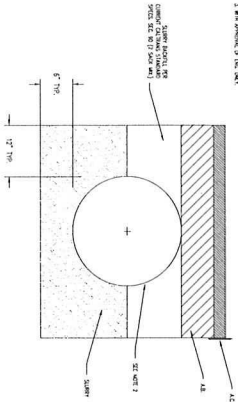

3 SLURRY CAP DETAIL
NTS

- NOTES:
1. 12" DIA. PIPE SHALL BE SET IN 4" MIN. CONC. BASE.
 2. 1/2" DIA. ADAPTER SHALL BE SET IN 4" MIN. CONC. BASE.
 3. 12" DIA. GRATE SHALL BE SET IN 4" MIN. CONC. BASE.
 4. 1/2" DIA. ADAPTER SHALL BE SET IN 4" MIN. CONC. BASE.
 5. 12" DIA. GRATE SHALL BE SET IN 4" MIN. CONC. BASE.
 6. 1/2" DIA. ADAPTER SHALL BE SET IN 4" MIN. CONC. BASE.
 7. 12" DIA. GRATE SHALL BE SET IN 4" MIN. CONC. BASE.
 8. 1/2" DIA. ADAPTER SHALL BE SET IN 4" MIN. CONC. BASE.

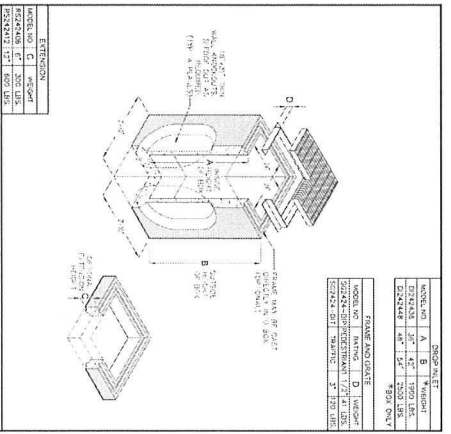

2 24" X 24" DRAINAGE INLET
NTS

24" X 24" DRAINAGE INLET
D/2424

INSTALLATION INSTRUCTIONS:
1. PREPARE SUBGRADE TO BE FLAT AND FIRM.
2. SET INLET ON SUBGRADE.
3. SET INLET ON SUBGRADE.
4. SET INLET ON SUBGRADE.
5. SET INLET ON SUBGRADE.

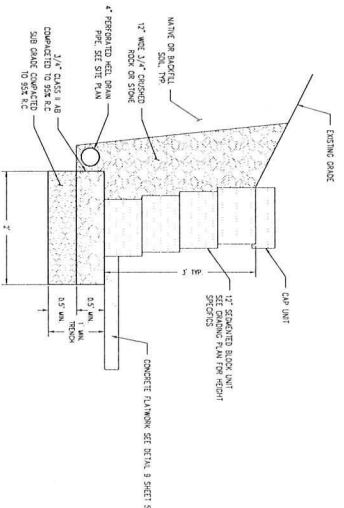

4 KEYSTONE LANDSCAPE WALL
NTS

- NOTES:
1. 12" DIA. PIPE SHALL BE SET IN 4" MIN. CONC. BASE.
 2. 1/2" DIA. ADAPTER SHALL BE SET IN 4" MIN. CONC. BASE.
 3. 12" DIA. GRATE SHALL BE SET IN 4" MIN. CONC. BASE.
 4. 1/2" DIA. ADAPTER SHALL BE SET IN 4" MIN. CONC. BASE.
 5. 12" DIA. GRATE SHALL BE SET IN 4" MIN. CONC. BASE.
 6. 1/2" DIA. ADAPTER SHALL BE SET IN 4" MIN. CONC. BASE.
 7. 12" DIA. GRATE SHALL BE SET IN 4" MIN. CONC. BASE.
 8. 1/2" DIA. ADAPTER SHALL BE SET IN 4" MIN. CONC. BASE.

	DESIGNED: JIB	NO. REVISIONS	DATE
	DRAWN: NJB		
	PROJ. NO: 202306		
	DATE: MAY, 2023		
	DWG: SEE DAY STAMP		

CIVIL IMPROVEMENT PLANS
SUTTON WAY WELLNESS CENTER
DRAINAGE / WALL DETAILS

GRASS VALLEY CALIFORNIA

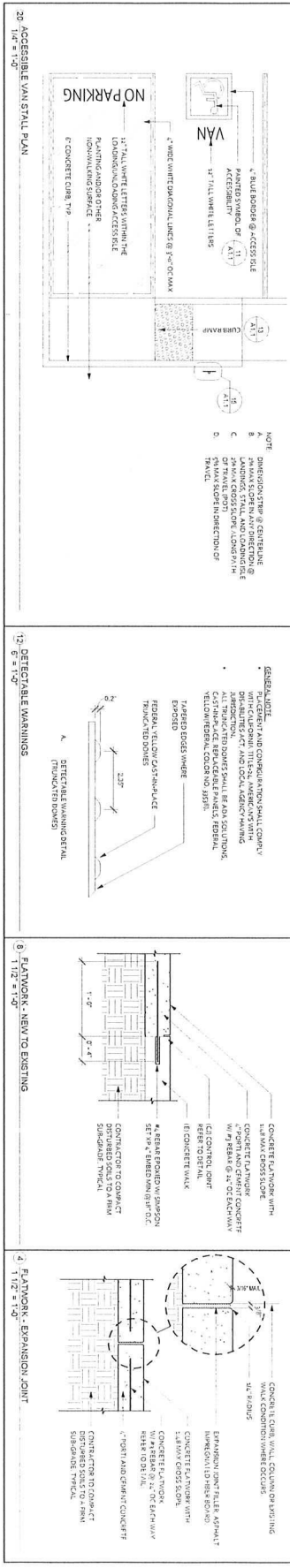
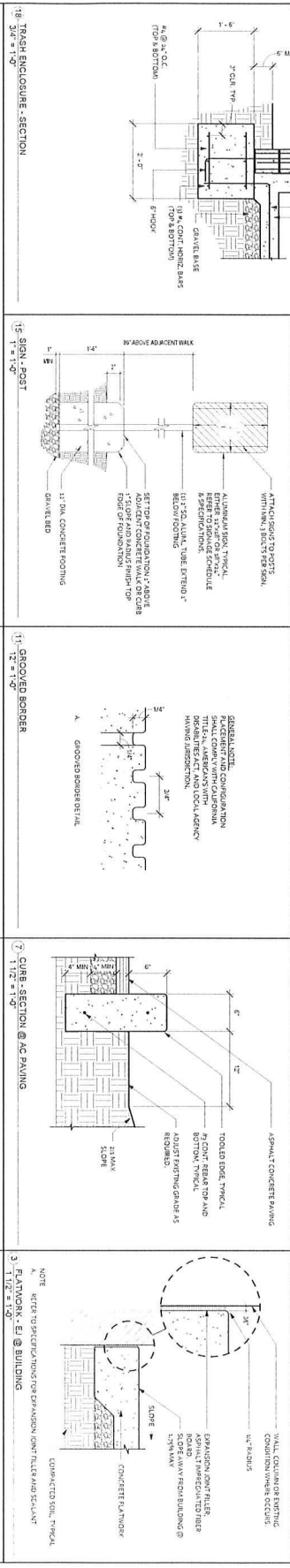
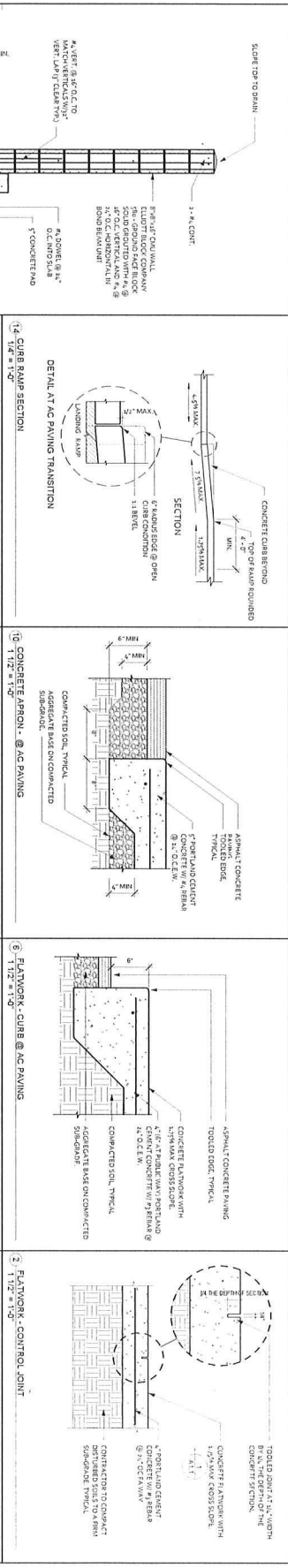
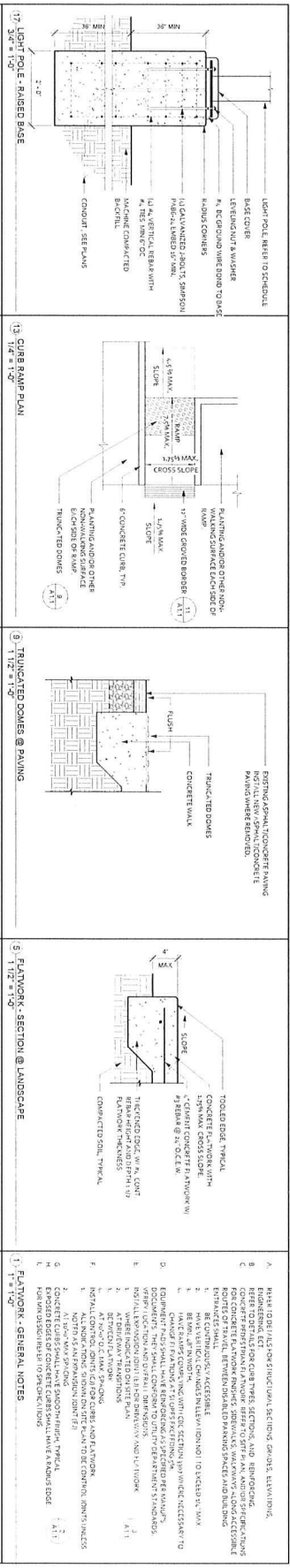

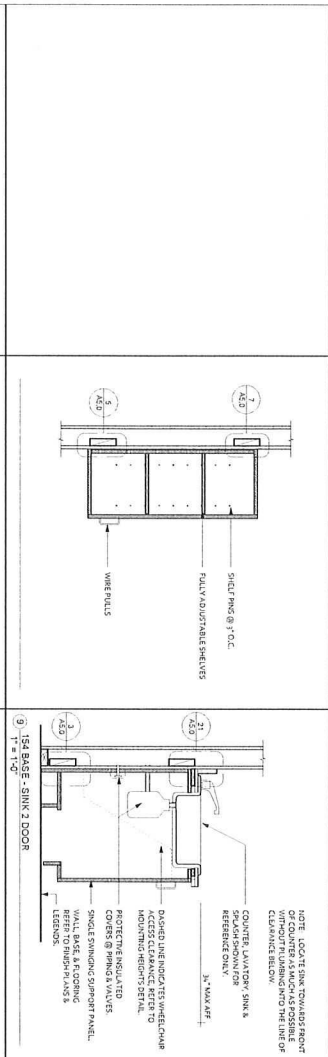

NOTE: LOCATE SINK TOWARD FRONT OF COUNTER AS MUCH AS POSSIBLE TO CLEARANCE BELOW.

COUNTER: LAMINATE, SINK & REFERENCED ONLY.

1" MAX AFF

3/4\"/>

Schedule - Equipment				Schedule - Casework							
Mark	Type	Manufacturer	Model	Mark	Description	Width	Height	Depth	QOS	Finish	Schedule Note
EQ1	Food Dispenser/Commercial Dishwasher	Greiner	710	1	Base Cabinet no Drawers	3'-0"	3'-0"	18"	L1		
EQ2	Commercial Dishwasher	Greiner	710	2	Wall Mount Cabinet	3'-0"	3'-0"	18"	L1		
EQ3	Commercial Dishwasher	Greiner	710	3	Wall Mount Cabinet	3'-0"	3'-0"	18"	L1		
EQ4	Food Dispenser	Greiner	710	4	Base Cabinet w/ Drawers	3'-0"	3'-0"	18"	L1		
EQ5	Food Dispenser	Greiner	710	5	Base Cabinet w/ Drawers	3'-0"	3'-0"	18"	L1		
EQ6	Food Dispenser	Greiner	710	6	Base Cabinet w/ Drawers	3'-0"	3'-0"	18"	L1		
EQ7	Food Dispenser	Greiner	710	7	Base Cabinet w/ Drawers	3'-0"	3'-0"	18"	L1		
EQ8	Food Dispenser	Greiner	710	8	Base Cabinet w/ Drawers	3'-0"	3'-0"	18"	L1		
EQ9	Food Dispenser	Greiner	710	9	Base Cabinet w/ Drawers	3'-0"	3'-0"	18"	L1		
EQ10	Food Dispenser	Greiner	710	10	Base Cabinet w/ Drawers	3'-0"	3'-0"	18"	L1		
EQ11	Food Dispenser	Greiner	710	11	Base Cabinet w/ Drawers	3'-0"	3'-0"	18"	L1		
EQ12	Food Dispenser	Greiner	710	12	Base Cabinet w/ Drawers	3'-0"	3'-0"	18"	L1		
EQ13	Food Dispenser	Greiner	710	13	Base Cabinet w/ Drawers	3'-0"	3'-0"	18"	L1		
EQ14	Food Dispenser	Greiner	710	14	Base Cabinet w/ Drawers	3'-0"	3'-0"	18"	L1		
EQ15	Food Dispenser	Greiner	710	15	Base Cabinet w/ Drawers	3'-0"	3'-0"	18"	L1		
EQ16	Food Dispenser	Greiner	710	16	Base Cabinet w/ Drawers	3'-0"	3'-0"	18"	L1		
EQ17	Food Dispenser	Greiner	710	17	Base Cabinet w/ Drawers	3'-0"	3'-0"	18"	L1		
EQ18	Food Dispenser	Greiner	710	18	Base Cabinet w/ Drawers	3'-0"	3'-0"	18"	L1		
EQ19	Food Dispenser	Greiner	710	19	Base Cabinet w/ Drawers	3'-0"	3'-0"	18"	L1		
EQ20	Food Dispenser	Greiner	710	20	Base Cabinet w/ Drawers	3'-0"	3'-0"	18"	L1		

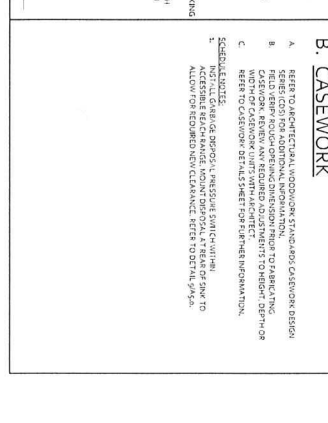
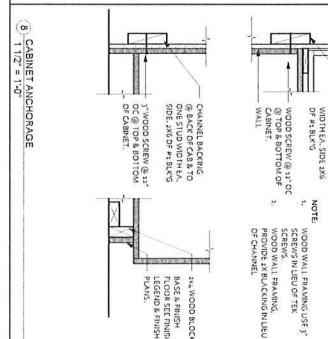
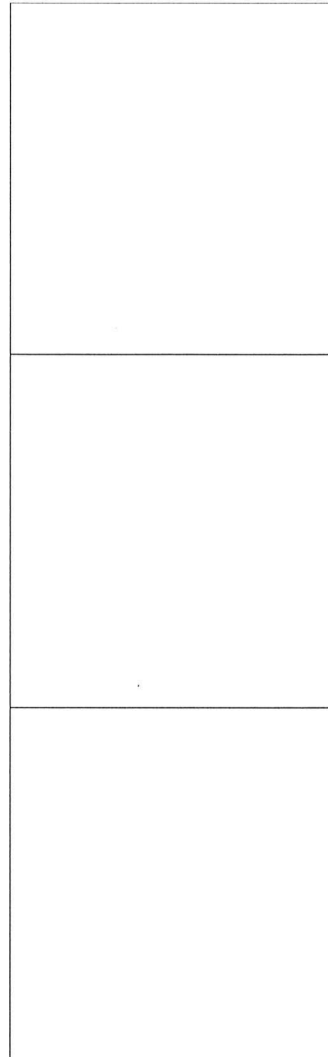
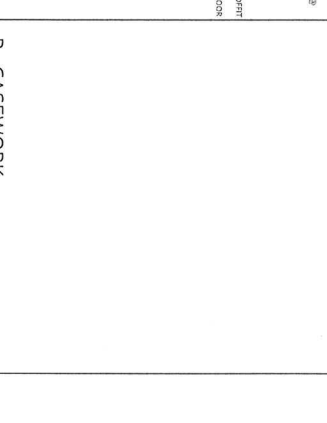
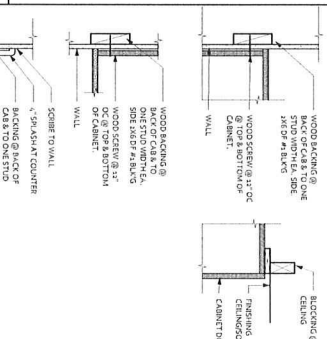
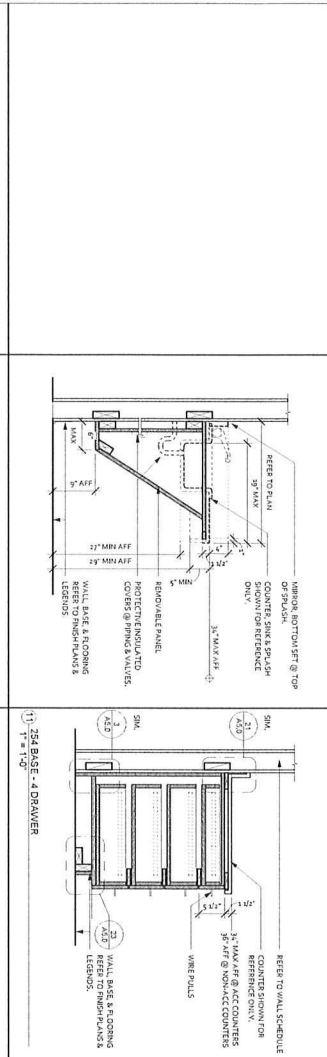
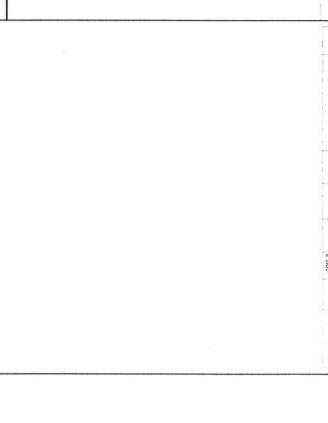
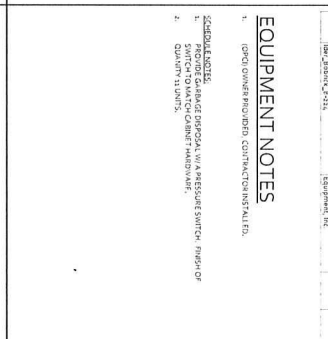
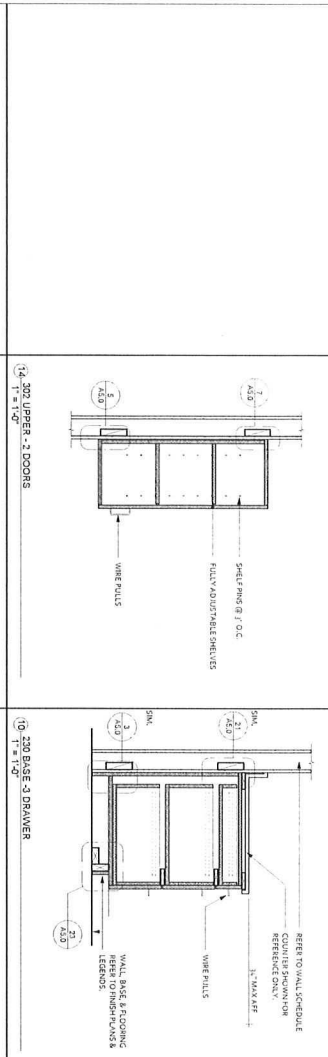

EQUIPMENT NOTES

1. UNIFORMS/SHOES/COMBINATION/STAL.
2. SWITCH TO MATCH CABINET HANDBARS.
3. CABINET TIDY.

SCHEMATIC NOTES

1. BACK OF CASE TO DIE 1/8" OF 1/4" BLVD.
2. WOOD SCREWS @ 3" OC @ TOP & BOTTOM OF CABINET.
3. WOOD SCREWS @ SIDE W/ 4" BLVD.
4. WOOD SCREWS @ 12" OF CABINET.
5. WOOD SCREWS @ 12" OF CABINET.
6. WOOD SCREWS @ 12" OF CABINET.
7. WOOD SCREWS @ 12" OF CABINET.
8. WOOD SCREWS @ 12" OF CABINET.
9. WOOD SCREWS @ 12" OF CABINET.
10. WOOD SCREWS @ 12" OF CABINET.
11. WOOD SCREWS @ 12" OF CABINET.
12. WOOD SCREWS @ 12" OF CABINET.
13. WOOD SCREWS @ 12" OF CABINET.
14. WOOD SCREWS @ 12" OF CABINET.
15. WOOD SCREWS @ 12" OF CABINET.
16. WOOD SCREWS @ 12" OF CABINET.
17. WOOD SCREWS @ 12" OF CABINET.
18. WOOD SCREWS @ 12" OF CABINET.
19. WOOD SCREWS @ 12" OF CABINET.
20. WOOD SCREWS @ 12" OF CABINET.

CASEWORK

- A. REFER TO ARCHITECTURAL WOODWORK STANDARDS CASEWORK DESIGN.
- B. REFER TO ARCHITECTURAL WOODWORK STANDARDS CASEWORK DESIGN.
- C. REFER TO ARCHITECTURAL WOODWORK STANDARDS CASEWORK DESIGN.
- D. REFER TO ARCHITECTURAL WOODWORK STANDARDS CASEWORK DESIGN.
- E. REFER TO ARCHITECTURAL WOODWORK STANDARDS CASEWORK DESIGN.
- F. REFER TO ARCHITECTURAL WOODWORK STANDARDS CASEWORK DESIGN.
- G. REFER TO ARCHITECTURAL WOODWORK STANDARDS CASEWORK DESIGN.
- H. REFER TO ARCHITECTURAL WOODWORK STANDARDS CASEWORK DESIGN.
- I. REFER TO ARCHITECTURAL WOODWORK STANDARDS CASEWORK DESIGN.
- J. REFER TO ARCHITECTURAL WOODWORK STANDARDS CASEWORK DESIGN.
- K. REFER TO ARCHITECTURAL WOODWORK STANDARDS CASEWORK DESIGN.
- L. REFER TO ARCHITECTURAL WOODWORK STANDARDS CASEWORK DESIGN.
- M. REFER TO ARCHITECTURAL WOODWORK STANDARDS CASEWORK DESIGN.
- N. REFER TO ARCHITECTURAL WOODWORK STANDARDS CASEWORK DESIGN.
- O. REFER TO ARCHITECTURAL WOODWORK STANDARDS CASEWORK DESIGN.
- P. REFER TO ARCHITECTURAL WOODWORK STANDARDS CASEWORK DESIGN.
- Q. REFER TO ARCHITECTURAL WOODWORK STANDARDS CASEWORK DESIGN.
- R. REFER TO ARCHITECTURAL WOODWORK STANDARDS CASEWORK DESIGN.
- S. REFER TO ARCHITECTURAL WOODWORK STANDARDS CASEWORK DESIGN.
- T. REFER TO ARCHITECTURAL WOODWORK STANDARDS CASEWORK DESIGN.
- U. REFER TO ARCHITECTURAL WOODWORK STANDARDS CASEWORK DESIGN.
- V. REFER TO ARCHITECTURAL WOODWORK STANDARDS CASEWORK DESIGN.
- W. REFER TO ARCHITECTURAL WOODWORK STANDARDS CASEWORK DESIGN.
- X. REFER TO ARCHITECTURAL WOODWORK STANDARDS CASEWORK DESIGN.
- Y. REFER TO ARCHITECTURAL WOODWORK STANDARDS CASEWORK DESIGN.
- Z. REFER TO ARCHITECTURAL WOODWORK STANDARDS CASEWORK DESIGN.

SCHEMATIC NOTES

1. ALL CASEWORK SHALL BE MEASURED FROM CENTERLINE.
2. ALL CASEWORK SHALL BE MEASURED FROM CENTERLINE.
3. ALL CASEWORK SHALL BE MEASURED FROM CENTERLINE.
4. ALL CASEWORK SHALL BE MEASURED FROM CENTERLINE.
5. ALL CASEWORK SHALL BE MEASURED FROM CENTERLINE.
6. ALL CASEWORK SHALL BE MEASURED FROM CENTERLINE.
7. ALL CASEWORK SHALL BE MEASURED FROM CENTERLINE.
8. ALL CASEWORK SHALL BE MEASURED FROM CENTERLINE.
9. ALL CASEWORK SHALL BE MEASURED FROM CENTERLINE.
10. ALL CASEWORK SHALL BE MEASURED FROM CENTERLINE.
11. ALL CASEWORK SHALL BE MEASURED FROM CENTERLINE.
12. ALL CASEWORK SHALL BE MEASURED FROM CENTERLINE.
13. ALL CASEWORK SHALL BE MEASURED FROM CENTERLINE.
14. ALL CASEWORK SHALL BE MEASURED FROM CENTERLINE.
15. ALL CASEWORK SHALL BE MEASURED FROM CENTERLINE.
16. ALL CASEWORK SHALL BE MEASURED FROM CENTERLINE.
17. ALL CASEWORK SHALL BE MEASURED FROM CENTERLINE.
18. ALL CASEWORK SHALL BE MEASURED FROM CENTERLINE.
19. ALL CASEWORK SHALL BE MEASURED FROM CENTERLINE.
20. ALL CASEWORK SHALL BE MEASURED FROM CENTERLINE.

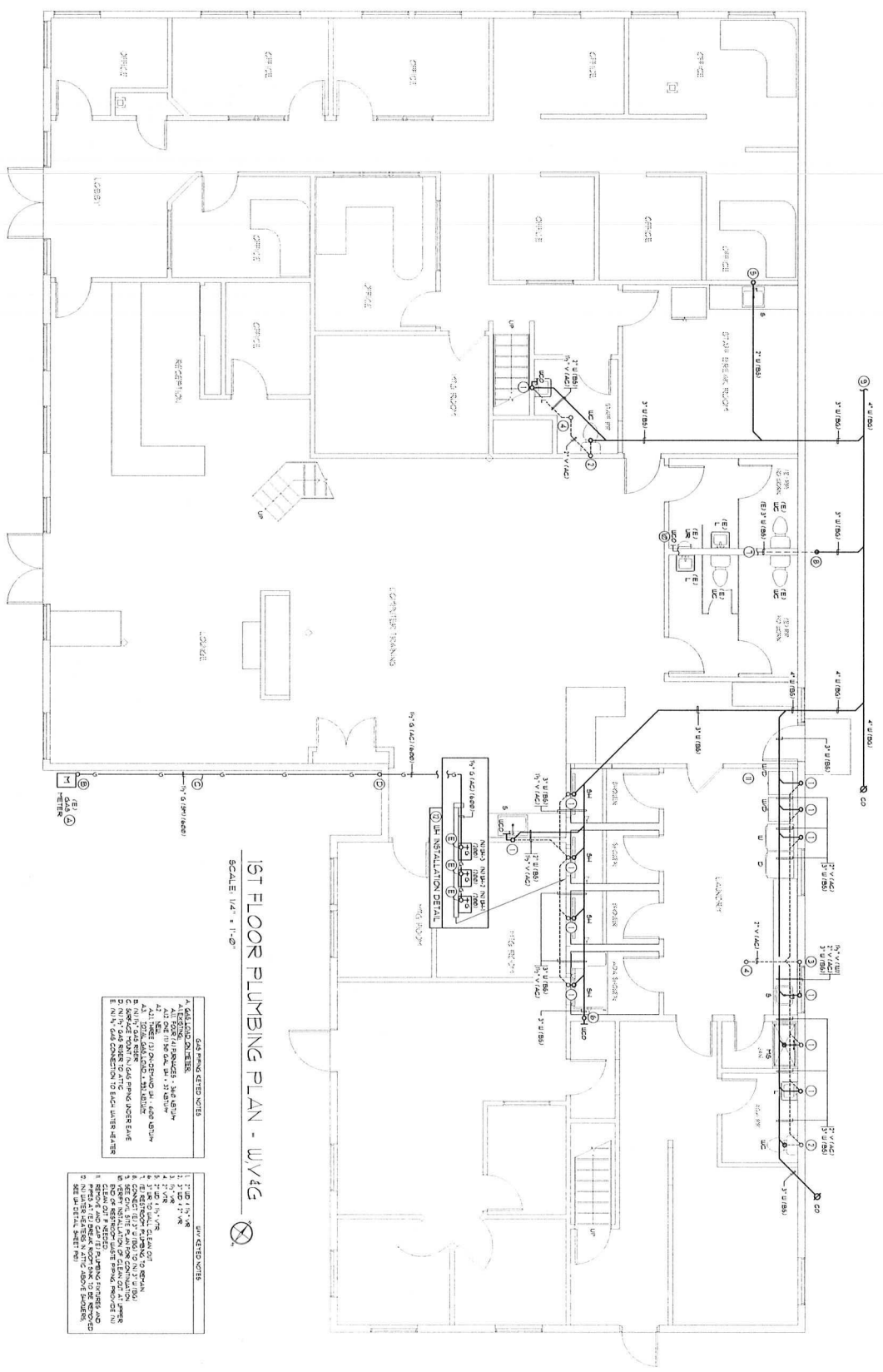

1ST FLOOR PLUMBING PLAN - WVG
 SCALE: 1/4" = 1'-0"

- | DATE CHANGED | |
|--------------|----------|
| 1 | 11/14/14 |
| 2 | 11/14/14 |
| 3 | 11/14/14 |
| 4 | 11/14/14 |
| 5 | 11/14/14 |
| 6 | 11/14/14 |
| 7 | 11/14/14 |
| 8 | 11/14/14 |
| 9 | 11/14/14 |
| 10 | 11/14/14 |
| 11 | 11/14/14 |
| 12 | 11/14/14 |

		ENERGY SOLUTIONS CONSULTANTS 541 BEN STREET NILES, CA 94565 TEL: (925) 753-4400 FAX: (925) 753-2773
		NC - HOMELESS RESOURCE CENTER 1105 SUTTON WAY GRASS VALLEY, CA 95945 1ST FLOOR PLUMBING PLAN - WVG
Project Title:	Project Location:	Sheet Title:
No.	Date:	By:
23-153	11/22/14	WVG
Scale:	Date:	Status:
as noted	N/A	P1.1

Client: Homeless Resource Center, 1105 Sutton Way, Grass Valley, CA 95945
 Project: 1105 Sutton Way, Grass Valley, CA 95945
 Date: 11/22/14
 Scale: as noted
 Status: P1.1

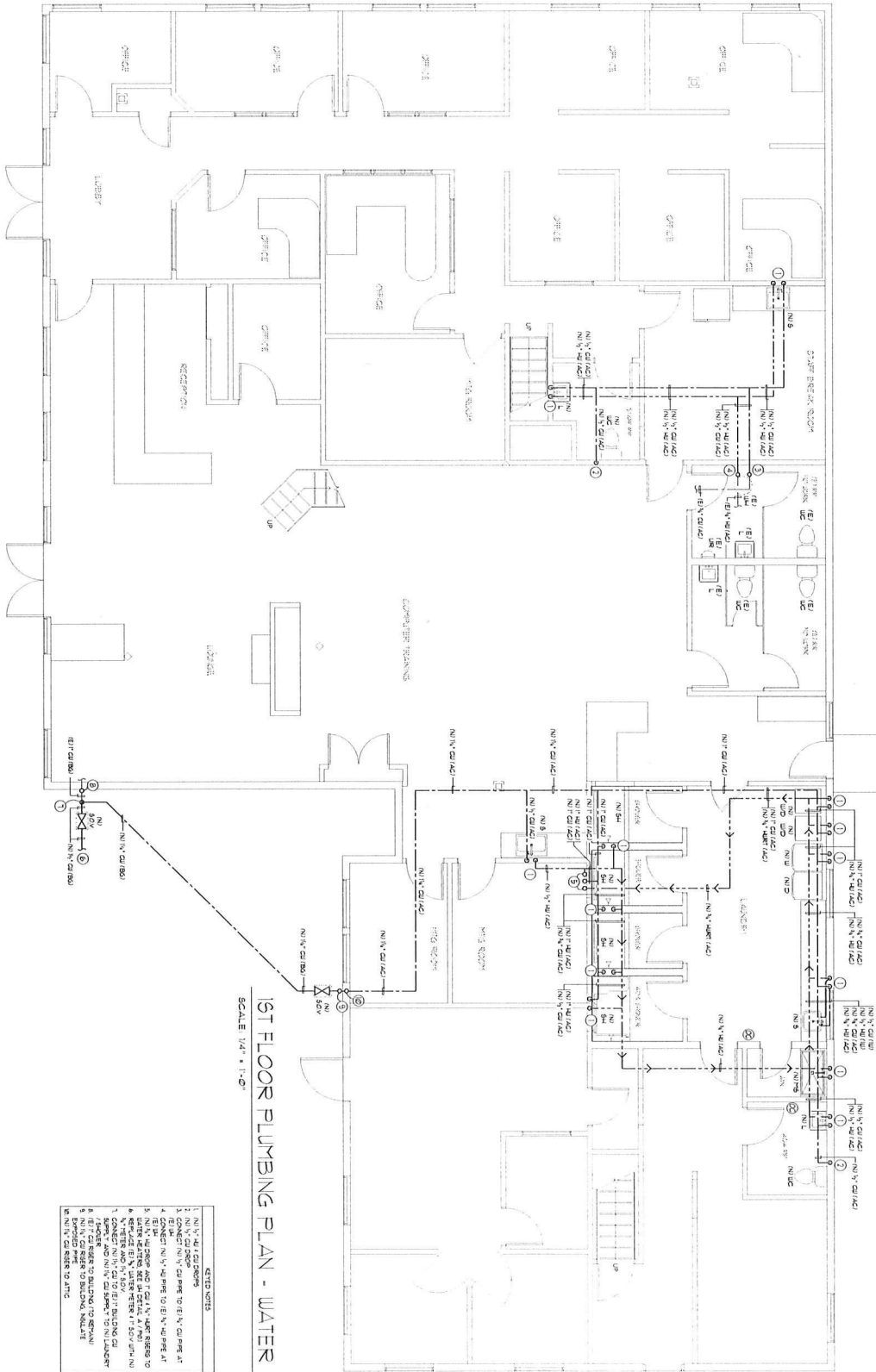

1ST FLOOR PLUMBING PLAN - WATER
SCALE 1/4" = 1'-0"

- NOTED NOTES**
1. (N) (V) - 1/2" CP WATER
 2. (N) (V) - CP WATER TO (E) (V) - CP WATER AT
 3. (E) (V) - CP WATER TO (E) (V) - CP WATER AT
 4. (E) (V) - CP WATER TO (E) (V) - CP WATER AT
 5. (N) (V) - CP WATER TO (E) (V) - CP WATER AT
 6. (N) (V) - CP WATER TO (E) (V) - CP WATER AT
 7. (N) (V) - CP WATER TO (E) (V) - CP WATER AT
 8. (N) (V) - CP WATER TO (E) (V) - CP WATER AT
 9. (N) (V) - CP WATER TO (E) (V) - CP WATER AT
 10. (N) (V) - CP WATER TO (E) (V) - CP WATER AT
 11. (N) (V) - CP WATER TO (E) (V) - CP WATER AT
 12. (N) (V) - CP WATER TO (E) (V) - CP WATER AT

		<p>ENERGY CONSULTING 1100 SUTTON WAY GRASS VALLEY, CA 95945 TEL: (530) 265-1173 FAX: (530) 265-1173</p>	
<p>PROJECT TITLE: NC - HOMELESS RESOURCE CENTER</p>			
<p>PROJECT LOCATION: 1105 SUTTON WAY GRASS VALLEY, CA 95945</p>			
<p>SHEET TITLE: 1ST FLOOR PLUMBING PLAN - WATER</p>			
<p>DATE: 11/20/2018</p>	<p>DATE: 11/20/2018</p>	<p>DATE: 11/20/2018</p>	<p>DATE: 11/20/2018</p>
<p>SCALE: as noted</p>	<p>SCALE: as noted</p>	<p>SCALE: as noted</p>	<p>SCALE: as noted</p>
<p>SHEET: P1.2</p>	<p>SHEET: P1.2</p>	<p>SHEET: P1.2</p>	<p>SHEET: P1.2</p>

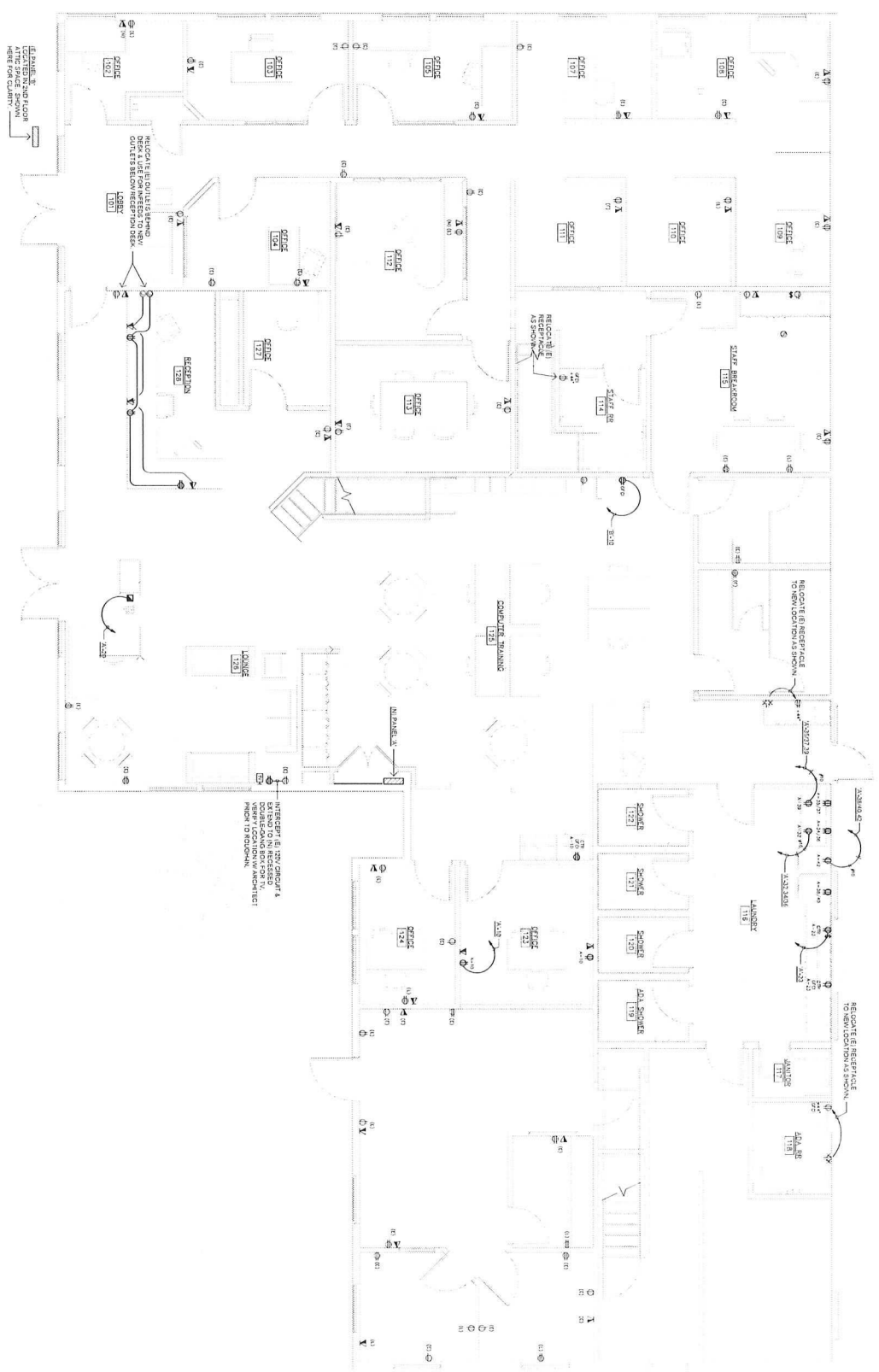

1 POWER & SIGNAL PLAN
SCALE: 1/8" = 1'-0"



WALLIS DESIGN STUDIO
ARCHITECTS, INC.
4415 Cornerwood Dr., Suite B
Hendrix City, CA 95959
Wallis@wallisdesign.com
www.wallisdesign.com

NC - HOMELESS
RESOURCE
CENTER

DATE SUBMITTED
11/15/2011
PROJECT NO.
2011-001
SCHEMATIC DESIGN

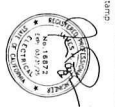

Date	Description

Project No.: 2011-001
Date: 11/15/2011
Scale: AS NOTED
Drawn By: JLJP

Drawing Title:
POWER & SIGNAL
PLAN

Drawing Number:
E2.0



AdamLabs, Inc.
3807 Pasadena Avenue, Suite 190
Sacramento, CA 95821
Phone: (916) 692-8355

Asbestos Report

Date: October 18, 2023

Client: Nevada County Housing & Community Services

Site: 1105 Sutton Way,
Grass Valley, CA

On October 16, 2023 an Asbestos Survey was conducted at the above location. Site inspection, sample collection, laboratory analyses, and written report are attached. The inspection area is an commercial suite currently planned for renovation/restoration. Therefore, building materials will be impacted during the planned renovation in specific to isolated areas of the structure. An assessment of the mentioned materials throughout the areas of impact was made and samples were collected according to the contractor's scope of work. This asbestos survey was conducted to confirm whether or not asbestos is identified in all suspected building material. Please see attached data sheet LAB #23AB2759

Results indicate No Asbestos was detected. The information provided in this report can be used to obtain accurate bids from abatement contractors. Based on sample results, no asbestos was detected in the suspected building materials tested. All other materials that are not part of this survey shall be treated as asbestos containing material until proven otherwise by PLM analyses. The above site address falls under the jurisdiction and is subject to the requirements of the local Air Quality Resource Board. The building materials sample collection was conducted by a State OSHA Certified "Site Surveillance Technician" and/or "Asbestos Consultant" under Adam Labs, Inc. (in accordance with Rule 902 Section 401.3). The location of asbestos containing material, quantity, percent, friability, type of asbestos, and date sampled can be found on the attached analytical lab report.

Approved by,

Adam Jahnsen, Certified Asbestos Consultant, DOSH #00-2813

Any building materials not mentioned in this report should be assumed as ACM until proven otherwise through proper sampling and analysis. This includes other areas that are not mentioned with similar materials. Upon discovery of unmentioned material, work must cease until further sampling is conducted.
This document is filed under lab identification number 23ABR2759



AdamLabs, Inc.

3807 Pasadena Ave. Ste., 190
Sacramento, CA 95821
Phone: (916)692-8344
Email: info@adamlabs.com

AIHA Laboratory #163722

Lab #: 23AB2759
Date Sampled: 10/12/1902
Date Analyzed: 10/18/2023
Sampled By: Adam Jahnsen
Analyzed By: Adam Jahnsen

Assessment and Analysis of Bulk Asbestos by Polarized Light Microscopy (PLM) EPA 600/M4 Method

CLIENT: Nevada County Housing &
Community Services

SITE: 1105 Sutton Way
Grass Valley, CA

No.	LAYERS	AREA FT ²	LOCATION	DESCRIPTION	I.D.	RACM	RESULT
1	1	*	file room floor	carpet glue	Cellulose Fibers		NAD
2	2	*	S center office wall	texture coat w/paint	Cellulose Fibers		NAD
3	5	*	S center office wall	joint compound w/sheetrock	Cellulose Fibers		NAD
4	5	*	center wall	joint compound w/sheetrock	Cellulose Fibers		NAD
5	2	*	center wall	texture coat w/paint	Cellulose Fibers		NAD
6	2	*	center W room S wall	texture coat w/paint	Cellulose Fibers		NAD
7	5	*	center W room S wall	joint compound w/sheetrock	Cellulose Fibers		NAD
8	5	*	center E room W wall	joint compound w/sheetrock	Cellulose Fibers		NAD
9	2	*	center E room W wall	texture coat w/paint	Cellulose Fibers		NAD
10	2	*	center pony wall	texture coat w/paint	Cellulose Fibers		NAD
11	5	*	center pony wall	joint compound w/sheetrock	Cellulose Fibers		NAD

LEGEND

NAD = Non Asbestos Detected. DL = detection limit: <1% asbestos (trace). I.D. = fiber identification and/or asbestos type - percent.

Friable Asbestos = NESHAP RACM (Regulated Asbestos Containing Material): can be crumbled, pulverized or reduced to powder by hand pressure.

Non-friable Asbestos = NESHAP Category I material (resilient floor covering, vinyl floor tile, asphalt roofing products, packings and gaskets that cannot be rendered airborne by hand pressure) and/or NESHAP Category II material (all other non-friable asbestos containing material). Note that because of age or treatment, Category I and Category II materials, can be, and/or have the potential to become RACM.

RACM = NESHAP Regulated Asbestos Containing Material is all Friable ACM (>1% asbestos), including some conditions of Non-friable Category I & II ACM.

NESHAP = US EPA National Emissions Standards for Hazardous Air Pollutants

APPROVED BY:

Adam Jahnsen, Lab Director
Certified Asbestos Consultant
CAL/OSHA: 00-2813

Analytical results represent the analysis of samples collected by AdamLab INC. This report is generated at the request and for the exclusive use of the person or entity (client) named on such report. Results, reports or copies will not be released to a third party without written request from the client. Sample(s) will be retained for a period of twelve months for possible future analytical verification, after which, the sample(s) will be disposed of according to all state and federal guidelines. AdamLabs Inc. is a participant in the BAPAT (Bulk Asbestos Proficiency Analytical Testing) quality assurance program by AIHA (American Industrial Hygiene Association).