



# RESOLUTION No. 16-425

## OF THE BOARD OF SUPERVISORS OF THE COUNTY OF NEVADA

### RESOLUTION APPROVING CONSTRUCTION DOCUMENTS AND AUTHORIZING THE PURCHASING AGENT TO SOLICIT BIDS FOR THE JOSEPH CENTER REAR ENTRANCE IMPROVEMENTS PROJECT

WHEREAS, the Truckee Joseph Center rear entrance is in need of repairs due to dry rot of support beams and other issues; and

WHEREAS, the Chief Information Officer has prepared construction documents for the project known as the Joseph Center Rear Entrance Improvements; and

WHEREAS, funding for this project will be paid from the Facilities Management Fiscal Year 2016-17 budget and partially reimbursed by the Judicial Council of California according to the terms of the Joint Operating Agreement between the County and the Judicial Council with respect to the Joseph Center.

NOW, THEREFORE, BE IT RESOLVED that the Nevada County Board of Supervisors hereby directs that the construction documents are approved and the Purchasing Agent is directed to solicit bids for this project.

PASSED AND ADOPTED by the Board of Supervisors of the County of Nevada at a special meeting of said Board, held on the 16th day of August, 2016, by the following vote of said Board:

Ayes: Supervisors Nathan H. Beason, Edward Scofield, Dan Miller, Hank Weston and Richard Anderson.

Noes: None.

Absent: None.

Abstain: None.

ATTEST:

JULIE PATTERSON HUNTER  
Clerk of the Board of Supervisors

By: 

  
Dan Miller, Chair

8/16/2016 cc: Facilities\*  
AC\*  
Purchasing\*

**County of Nevada  
Information & General Services Department  
Purchasing Division**



Invitation for Bid

For

**Joseph Center Rear Entrance Improvements**

**Bids Due: 2:30 p.m., Tuesday, September 6, 2016**

**Date issued: August 16, 2016**

**Pre-Bid Site Visit (recommended)**

**10:00 p.m., Wednesday, August 24, 2016**

at:

**Joseph Center (in the rear)  
10075 Levon Ave  
Truckee, CA 96161**

**BIDDING DOCUMENTS, SPECIFICATIONS  
AND CONTRACT DOCUMENTS  
(Standard Public Works Contract)**

**CONTRACT TIME LINE**

1. **BIDS DUE: 2:30 p.m, Tuesday, September 6, 2016**  
(See page 3 of Invitation for Bid)
2. **BID OPENING: 2:30 p.m, Tuesday, September 6, 2016**  
(See page 3 of Invitation for Bid)
3. BIDS TO REMAIN OPEN FOR **60** DAYS FROM DATE OF OPENING OF BIDS (See paragraph 21 of Instructions to Bidders)
4. NOTICE OF AWARD DUE WITHIN **30** DAYS OF OPENING OF BIDS (See paragraph 23 of Instructions to Bidders and same as 3 above)
5. BID BONDS OF UNSUCCESSFUL BIDDERS TO BE RETURNED WITHIN **10** DAYS OF AWARD BY COUNTY (See paragraph 18 of Instructions to Bidders)
6. CONTRACT SIGNING AND BONDS DUE WITHIN **5** DAYS OF NOTICE OF AWARD (See paragraph 24 and 26 of Instructions to Bidders)
7. NOTICE TO PROCEED WITH WORK DUE WITHIN **15** DAYS OF CONTRACT SIGNING (See paragraph 25 of Instructions to Bidders)
8. CONSTRUCTION MUST BEGIN WITHIN **10** DAYS AFTER MAILING OF NOTICE TO PROCEED (See paragraph 2 of Contract)
9. CONTRACTOR MUST GIVE 72 HOURS WRITTEN NOTICE OF DATE WORK WILL COMMENCE.
10. PRECONSTRUCTION CONFERENCE WITHIN **5** DAYS OF NOTICE TO PROCEED (See Article III of Contract)
11. SCHEDULES AND BREAKDOWN OF PHASES OF CONSTRUCTION DUE IN **7** DAYS AFTER RECEIPT OF NOTICE TO PROCEED (See Article III of Contract)
12. WORK MUST BE COMPLETED WITHIN **60** DAYS OF MAILING OF THE NOTICE TO PROCEED (See Article III of Contract)

**INVITATION FOR BID**

FOR: **Joseph Center Rear Entrance Improvements**  
LOCATED AT: **Joseph Center, 10075 Levon Ave, Truckee, CA 96161**

Sealed bids will be received at the office of the:

Purchasing Division  
c/o Auditor/Controller Office  
County of Nevada  
950 Maidu Ave.  
Nevada City, California 95959

Until **2:30 p.m.** local time on **Tuesday, September 6, 2016** for the above referenced project.

Bids received after said time will not be accepted and will be returned unopened.

At said place and time, and promptly thereafter, all bids that have been properly submitted will be publicly opened and read aloud. All interested parties are invited to attend.

The work to be performed includes the following:

**Make improvements to the rear entry to the Joseph Center according to the plans and specifications including but not limited to: demolition of existing concrete, replacing structural framing, new concrete stem walls, entry and steps, and asphalt work.**

Bids shall be: **Lump Sum.**

Bids must be for all of the work described herein unless the bid form specifically indicates a bid item is optional.

Plans, specifications, proposal forms, project manuals and all documents relating to this project can only be obtained at the office or website of the:

Purchasing Division  
County of Nevada  
950 Maidu Ave.  
Nevada City, California 95959

[www.mynevadacounty.com/nc/igs/purchasing](http://www.mynevadacounty.com/nc/igs/purchasing) under *Current Requests for Bids and Proposals*. Vendors must register with the County in order to be notified of addenda and other notices. To register, please send an email to [sandy.balzer@co.nevada.ca.us](mailto:sandy.balzer@co.nevada.ca.us) indicating **Joseph Center Rear Entrance Improvements** in the title. If you do not receive a reply to this email indicating that you have been registered, please call 530-265-1747.

The County will not be providing printed copies of the plans to bidders for this project.

Contractor will be required to possess a **B** contractor's license at the time the bid is submitted.

All written requests, correspondence and/or communications of any kind regarding the project, including any sealed bids which are submitted by mail, shall be addressed to:

Purchasing Division  
County of Nevada

950 Maidu Ave.  
Nevada City, California 95959

**A pre-bid walk-through will be held beginning at 10:00 a.m., Wednesday, August 24, 2016 at the project site at the Joseph Center, 10075 Levon Ave, Truckee, CA 96161**

Bids will be accepted from bidders who did not attend the pre-bid conference, but bidders will be charged with all of the information disseminated at the pre-bid conference as if they had been present. All written questions or other correspondence regarding the plans and specifications must be received by **3:00 p.m. on Friday August 26, 2016** and shall be addressed to:

Purchasing Division                      Phone: 530-265-1747  
County of Nevada                          Fax: 530-265-7112  
950 Maidu Ave.  
Nevada City, California 95959  
[sandy.balzer@co.nevada.ca.us](mailto:sandy.balzer@co.nevada.ca.us)

Bids shall be received by **2:30 p.m., Tuesday, Sept 6, 2016**. For all bids over \$25,000, each bidder must submit a cashier's check, certified check or a bidder's bond in an amount equal to 10% of the total amount of the bid.

The bidder to whom a contract is awarded will be required to furnish a performance bond and a labor and materials bond guaranteeing faithful performance and payment of all debts related to this contract.

The County of Nevada, in accordance with Title VI of the Civil Rights Act of 1964 (78 Stat. 252) and the regulations of the Department of Commerce (15 C.F.R., Part 8), issued pursuant to such Act, hereby notifies all bidders that it will affirmatively ensure that in any contract entered into pursuant to this advertisement, minority business enterprises will be afforded full opportunity to submit bids in response to this invitation and will not be discriminated against on the grounds of race, color, or national origin in consideration for an award.

This is a public works project, subject to the prevailing wage requirements of the California Labor Code. Copies of the prevailing rate of per diem wages are available at the California Department of Industrial Relations web site [www.dir.ca.gov/DLSR/PWD/](http://www.dir.ca.gov/DLSR/PWD/). Contractor shall not pay less than the prevailing rate of wages. No contractor or subcontractor may be listed on a bid proposal for a public works project (submitted on or after March 1, 2015), unless registered with the Department of Industrial Relations pursuant to Labor Code section 1725.5 [with limited exceptions from this requirement for bid purposes only under Labor Code section 1771.1(a)]. No contractor or subcontractor may be awarded a contract for public work on a public works project (awarded on or after April 1, 2015) unless registered with the Department of Industrial Relations pursuant to Labor Code section 1725.5. This project is subject to compliance monitoring and enforcement by the Department of Industrial Relations.

No bid will be considered unless it is made on a form furnished by the County of Nevada and is made in accordance with the provisions of the proposal requirements and conditions set forth in the contract documents.

The County of Nevada reserves the right to reject any or all bids.

DATED: \_\_\_\_\_

COUNTY OF NEVADA  
STATE OF CALIFORNIA

By \_\_\_\_\_  
Chairman, Board of Supervisors or  
Purchasing Agent

## INSTRUCTIONS TO BIDDERS

FOR: Joseph Center Rear Entrance Improvements

LOCATED AT: **Joseph Center, 10075 Levon Ave, Truckee, CA 96161**

### 1. DEFINITIONS

Bidder: One who submits a bid directly to County as distinct from a sub-bidder who submits a bid to a bidder.

Successful Bidder: The lowest, qualified, responsive, responsible bidder to whom County makes an award.

Bidding Documents:

- Invitation for Bid
- Instruction to Bidders
- Bid Form
- Bidders Bond or other security
- Experience Statement
- Subcontractor Listing
- Bidder's Representations
- Proposed Contract Documents
- Any and all Addenda

### 2. COPIES OF BIDDING DOCUMENTS

Complete copies of the bid documents and specifications for use in preparing bids may be obtained in accordance with the Invitation for Bid. Bid documents are also available electronically and can be downloaded from [www.mynevadacounty.com/purchasing](http://www.mynevadacounty.com/purchasing) under the Current Requests for Bids and Proposals section Requests For Proposal section. Addendums will also be posted to this location. Vendors must register with the County in order to be notified of addendums and other notices. To register, please send an email to [sandy.balzer@co.nevada.ca.us](mailto:sandy.balzer@co.nevada.ca.us) indicating **Joseph Center Rear Entrance Improvements** in the title. If you do not receive a reply to this email indicating that you have been registered, please call 530-265-1747.

Partial sets of bidding documents will not be issued. Complete sets of bidding documents shall be used in preparing bids. County assumes no responsibility for errors or misinterpretations resulting from the use of incomplete sets of bidding documents. If bidder believes its set of bidding documents is incomplete, it shall be the responsibility of bidder to contact County to confirm that Bidder has a complete set.

County, in making copies of bidding documents available on the above terms, does so only for the purpose of obtaining bids on the work and does not confer a license or grant for any other use.

### 3. QUALIFICATIONS OF BIDDERS

Each bidder must be prepared to submit, within five days of County's request, written evidence of bidder's qualifications to perform the work. Bidders may be required to submit evidence that they have a practical knowledge of the particular work bid upon, and that they have the financial resources to complete the proposed work. In determining the bidder's qualifications, the following factors will be considered: work previously completed by the bidder and whether the bidder (a) maintains a permanent place of business,

(b) has adequate plant and equipment to do the work properly and expeditiously, (c) has the financial resources to meet all obligations incident to the work, and (d) has appropriate technical experience. Each bidder may be required to show that he or she has handled former work so that no just claims are pending against such work. No bid will be accepted from a bidder who is engaged on any work which would impair his or her ability to perform or finance this work.

Each bidder must hold a current valid contractor's license at the time of bidding or the bid will be rejected.

#### **4. INSPECTION OF SITE OF WORK**

Bidders are required to inspect the site of the work in order to satisfy themselves, by personal examination or by such other means as they may prefer, of the location of the proposed work and as to the actual conditions of and at the site of work. If, during the course of the examination, bidder finds facts or conditions which appear confusing to bidder, bidder shall apply to County for additional information and explanation before submitting the bid. However, no such supplemental information so requested or furnished shall vary the terms of the specifications or the Contractor's sole responsibility to satisfy himself or herself as to the conditions of the work to be performed, unless an addendum has been issued.

The submission of a bid by the bidder shall constitute the acknowledgment that, if awarded the contract, bidder has relied and is relying on bidder's examination of (a) the site of the work, (b) the access to the site, and (c) all other data, matters, and things requisite to the fulfillment of the work and on bidder's own knowledge of existing conditions on and in the vicinity of the site of the work to be constructed under the contract, and not on any representation or warranty of County. No claim for additional compensation will be allowed which is based upon a lack of knowledge of the above items.

Where technical reports or data have been utilized in the preparation of the contract documents, bidder may rely upon the accuracy of the technical data contained in such reports but not upon the interpretations or opinions contained therein for the completeness thereof for the purpose of bidding or construction.

Where plans and specifications contain drawings of physical conditions in or relating to existing surface conditions, including underground facilities, which are at or contiguous to the site, bidder may rely upon the accuracy of the data contained in such drawings but not upon the completeness thereof for the purposes of bidding or construction. If a mass diagram has been prepared for a project, it is for design purposes only. If it is made available to bidders, County assumes no responsibility whatever for the information contained therein and makes no guarantees with respect to reliance thereon.

Before submitting a bid, each bidder will, at bidder's own expense, make or obtain any additional examinations, investigations, explorations, tests and studies and obtain any additional information and data which pertain to the physical conditions (surface, subsurface and underground facilities) at or contiguous to the site or otherwise which may affect cost, progress, performance or furnishing of the work and which bidder deems necessary to determine its bid for performing and furnishing the work in accordance with the time, price and other terms and conditions of the contract documents.

On request in advance, County will provide each bidder access to the site to conduct such explorations and tests as each bidder deems necessary for submission of a bid. Bidder shall fill all holes, clean up and restore the site to its former condition upon completion of such explorations.

The lands upon which the work is to be performed, rights-of-way and easements for access thereto and other lands designated for use by Contractor in performing the work are identified in the contract documents. All additional lands and access thereto required for temporary construction facilities or storage of materials and equipment are to be provided by Contractor. Easements for permanent structures or permanent changes in existing structures are to be obtained and paid for by County unless otherwise provided in the contract documents.

**5. EXAMINATION OF CONTRACT DOCUMENTS**

The contract documents shall consist of the following:

1. Invitation for Bid
2. Instruction to Bidders
3. Contractor's Bid (including documentation accompanying the Bid and any post-bid documentation submitted prior to the Notice of Award)
4. Contract
5. Addenda which pertain to the Contract
6. The Bonds or other security
7. Any supplementary conditions or any and all written agreements amending or extending the work, time or price contemplated
8. The Plans and Specifications and Drawings as identified in the Contract
9. Certificates of Insurance
10. Other: \_\_\_\_\_

Each bidder shall thoroughly examine and be familiar with legal and procedural documents, general conditions, specifications, drawings and addenda (if any). The submission of a bid shall constitute an acknowledgment upon which County may rely that the bidder has thoroughly examined and is familiar with the contract documents. The failure or neglect of a bidder to receive or examine any of the contract documents shall in no way relieve that bidder from any obligation with respect to that bidder's bid or to the contract. No claim for additional compensation will be allowed which is based upon a lack of knowledge of any contract documents.

**6. INTERPRETATION OF CONTRACT DOCUMENTS**

No oral representations or interpretations will be made to any bidder as to the meaning of the contract documents. Any ambiguities, inconsistencies in the plans and specifications or other contract documents, or problems which are visible by an inspection of the site or review of the contract documents shall be resolved prior to bidding. Request for an interpretation shall be made in writing and delivered to County at least 10 days before the time announced for opening the proposals. Interpretations by County will be in the form of an addendum to the contract documents and, when issued, will be sent as promptly as is practical to all parties to whom the bid documents have been issued. All such addenda shall become part of the contract. County reserves the right to amend any contract language which it determines is ambiguous prior to award of the bid.

**7. ADDENDA**

Each bid shall include specific acknowledgment, in the space provided, of receipt of all addenda issued during the bidding period. Failure to so acknowledge will result in the bid being rejected as not responsive. The Contractor is responsible for verifying that all addenda have been received and for obtaining all addenda prior to submitting bids for the work.

Only questions answered by formal written addenda will be binding. Oral and other interpretations or clarifications will be without legal effect.

Addenda may also be issued to modify the bidding documents as deemed advisable by County.

Addenda will be mailed or delivered to all parties recorded as having received the bidding documents. No addenda will be issued later than four days prior to the date for receipt of bids except an addendum, if necessary, postponing the date for receipt of bids or withdrawing the request for bids.



**8. BIDS**

Bids shall be made on the blank forms prepared by County and included herein. Bidders may extract these pages from the book of specifications or submit the entire book. All bids shall give prices, both in writing and in figures, and shall be signed by the bidder or bidder's authorized representative with bidder's address and shall provide all other information requested on the bid form. If the bid is made by an individual, his or her name, signature and post office address must be shown; if made by a firm or partnership, the name and post office address of the firm or partnership must be shown; if made by a corporation, the bid shall show the name of the state under the laws of which the corporation is chartered, the name and post office address of the corporation, and the title of the person who signs on behalf of the corporation.

**9. SUBMISSION OF BIDS**

Bids shall be submitted at the time and place indicated in the Invitation for Bid and shall be included in a sealed envelope addressed to the Nevada County Purchasing Division. If mailed, the bids shall be addressed to:

Purchasing Division  
County of Nevada  
950 Maidu Ave.  
Nevada City, California 95959

and if hand carried, delivered to the Purchasing Division, c/o Auditor/Controller Office, County of Nevada, 950 Maidu Avenue 2<sup>nd</sup> Floor, Nevada City,, California 95959.

The bid shall be identified on the outside with the bidder's name, license number and address and with the project title.

Each bid shall be accompanied by the bid security if bid over \$25,000 and other required documents.

If the bid is sent by mail, the sealed envelope shall be enclosed in a separate mailing envelope with the notation "BID ENCLOSED" with the Grass Valley Library Circulation Desk and Improvements on the face thereof.

Bids shall be deposited at the designated location prior to the time and date for receipt of bids indicated in the Invitation for Bid, or the modified time and date indicated by addendum. Bids received after the time and date for receipt of bids will be returned unopened. Bidder shall assume full responsibility for timely delivery at the location designated for receipt of bids.

Oral, telephone, or telegraph bids are invalid and will not receive consideration. No bidder may submit more than one bid. Multiple bids under different names will not be accepted from one firm or association.

**10. PRE-BID CONFERENCE OR WALK-THROUGH**

**A pre-bid conference or walk-through will be held at 10:00AM, Wednesday, August 24, 2016 , at the project site at Joseph Center, 10075 Levon Ave, Truckee, CA 96161.**

The representatives of County, any consultants and/or Project Engineer will be present to answer questions. Any questions which, in the opinion of County, cannot be answered by direct reference to the bidding documents will be answered by formal written addenda as outlined above.

The pre-bid conference or walk-through may include a tour of the site of the work conducted by representatives of County. All interested parties are invited to attend.

**11. BID PRICE**

The bid price shall include everything necessary for the completion of construction and fulfillment of the contract including, but not limited to, furnishing all materials, equipment, tools, plant and other facilities and all management, superintendence, labor and services, except as may be provided otherwise in the contract documents.

In the event of a difference between the price quoted in words and a price quoted in figures for the same quotation, the words shall be considered the amount bid. Discrepancies between the indicated sum or total of figures and the correct sum or total will be resolved in favor of the correct sum or total.

**12. BASIS OF BIDS**

The bidder shall submit both a lump sum price and prices for all unit cost items and alternatives shown on the bid form. Failure to comply may be cause for rejection.

Where specific quantities are given they are approximate only, being given as a basis for the comparison of bids, and the County of Nevada does not, expressly or by implication, warrant that the actual amount of work will correspond therewith, but reserves the right to increase or decrease the amount of any class or portion of the work or to omit portions of the work as may be deemed necessary or advisable by County. The amount of the bid for comparison purposes will be the total of all items. The total of unit basis items will be determined by extension of the item price bid on the basis of the estimated quantity set forth for the item.

The bidder shall set forth for each item of work, in clearly legible figures, an item price and a total for the item in the respective spaces provided for this purpose. In the case of unit basis items, the amount set forth under the "Total" column shall be the extension of the item price bid on the basis of the estimated quantity for the item.

In case of discrepancy between the item price and the total set forth for the item, the item price shall prevail; however, if the amount set forth as an item price is ambiguous, unintelligible or uncertain for any cause, or is omitted, or in the case of unit basis items is the same amount as the entry in the "Total" column, then the amount set forth in the "Total" column for the item shall prevail in accordance with the following:

- a. As to unit basis items, the amount set forth in the "Total" column shall be divided by the estimated quantity for the item and the price thus obtained shall be the item price.
- b. As to lump sum items, the amount set forth in the "Total" column shall be the item price.

In accordance with the provision of Section 6707 of the State Labor Code, each bidder shall list, in any bid item calling for trenching of 5 feet or more in depth, the amount contained in the proposal for adequate trench and excavation sheeting, shoring, and bracing or equivalent method for the protection of life and limb which shall conform to applicable Safety Orders.

**13. TAXES**

Bid prices shall include allowance for all federal, state and local taxes.

**14. CONTRACT TIME**

The date by which the work is to be completed (the contract time) is set forth in the contract documents.

**15. SUBSTITUTE MATERIAL AND EQUIPMENT**

The contract, if awarded, will be on the basis of material and equipment described in the drawings or specified in the specifications without consideration of possible substitute or "co-equal" items. Whenever it is indicated in the drawings or specified in the specifications that a substitute or "co-equal" item of material or equipment may be furnished or used by Contractor if acceptable to County, application for such acceptance will not be considered by County until after the effective date of the contract unless an addendum is issued to all bidders authorizing the use of a specified substitute. The procedure for submittal of any such application by Contractor and consideration by County is set forth in the contract documents.

**16. LIST OF SUBCONTRACTORS**

Each bid shall have listed on the form provided herewith the name and address of each subcontractor to whom the bidder proposes to sublet portions of the work in excess of one-half of one percent of the total amount of the bid or, in the case of bids for construction of streets or highways, including bridges, in excess of one-half of one percent of the Contractor's total bid or \$10,000, whichever is greater, per Public Contracts Code Section 4104. For the purpose of this paragraph, a subcontractor is defined as one who contracts with the Contractor to furnish materials and labor, or labor only for the performance of work at the site of the work.

County has the right to review the suitability and qualifications of any subcontractor or supplier proposed by the Contractor. As part of this review County may request an experience statement with pertinent information as to similar projects and other evidence of qualification for each such subcontractor, person and organization. If County, after due investigation, has reasonable objection to any proposed subcontractor, County may, before giving the notice of award, request the apparent successful bidder to submit an acceptable substitute without an increase in bid price. If the apparent successful bidder does not make such substitution, the contract shall not be awarded to such bidder, but Contractor's failure to make such substitution will not constitute grounds for sacrificing the bid security. Any subcontractor, other person or organization so listed and to whom County does not make written objection prior to the giving of the notice of award will be deemed acceptable to County subject to revocation of such acceptance after the effective date of the agreement as provided in the contract documents.

No Contractor shall be required to employ any subcontractor, other person or organization against whom Contractor has reasonable objection.

The Contractor may not change any subcontractor listed on its bid without written approval from County after a determination that the requirements of Public Contracts Code Section 4107 have been met.

**17. BID GUARANTY (BID BOND)**

Bid Guaranty (Bid Bond) is required on all bids over \$25,000. The bid shall be accompanied by a bid guaranty bond (bid bond) duly completed on the form provided herewith or a form which is substantially similar, by a guaranty company authorized to carry on business in the State of California, for payment to County in the sum of at least 10 percent of the total amount of the bid, or alternatively by a certified or cashier's check, payable to County in the sum of at least 10 percent of the total amount of the bid. A bid bond form which provides further payment of attorney's fees or which contains a termination date will not be considered to be "substantially similar". The amount payable to County under the guaranty bond, or

the certified or cashier's check and the amount thereof, as the case may be, shall be forfeited to County as liquidated damages in case of a failure or neglect of the bidder to furnish, execute and deliver to County the required performance and payment bonds, evidence of insurance, and to enter into, execute and deliver to County the contract on the form provided herewith, within **5** days after being notified in writing by County that the award has been made and the agreement is ready for execution.

All bonds shall have a power of attorney authorizing the signature of the person authorized to sign on behalf of the Surety attached to the bond. The power of attorney signature and the principal's signature shall each (both) be notarized.

The bid bond shall name County as beneficiary and shall specify that the bond is valid for the bid opening of this project as scheduled in the Invitation for Bid.

**18. RETURN OF BID GUARANTEES**

Within 10 days after the bids are awarded, County will return the bid guarantees (other than bid bonds) accompanying the bids for bids not considered in making the award. All other bid guaranties will be held until the contract has been fully executed, after which they will be returned to the respective bidders whose bids they accompany.

**19. MODIFICATION OR WITHDRAWAL OF BIDS**

Bids submitted early may be modified or withdrawn by notice to the party receiving bids at the place and prior to the time designated for receipt of bids. Such notice shall be in writing over the signature of the bidder or be by telegram; if by telegram, written confirmation over the signature of bidder must have been mailed and postmarked on or before the date and time set for receipt of bids; it shall be so worded as not to reveal the amount of original bid. Bids may also be modified or withdrawn in person by the bidder or an authorized representative provided bidder can prove bidder's identity and authority. Withdrawn bids may be resubmitted up to the time designated for the receipt of bids provided that they are then fully in conformance with these instructions to bidders.

If, within 24 hours after bids are opened, any bidder files a duly signed written notice with County and promptly thereafter demonstrates to the reasonable satisfaction of County that there was a material and substantial mistake in the preparation of the bid, that bidder may withdraw his or her bid and the bid security will be returned. Thereafter, that bidder will be disqualified from further bidding on the work.

**20. OPENING OF BIDS**

Bids will be opened publicly and read aloud. An abstract of the amounts of the base bids and major alternates (if any) will be made available after the opening of bids.

**21. BIDS TO REMAIN OPEN**

All bids shall remain open and subject to acceptance for a period of **60** days from the date of opening, but County may, in County's discretion, release any bid and return the bid security prior to that date.

**22. POSTPONEMENT OF OPENING**

County reserves the right to postpone the date and time for opening of bids at any time prior to the date and time announced in the advertisement.

**23. AWARD OF CONTRACT**

The award of the contract, if awarded, will be made to the lowest responsive, responsible bidder whose bid complies with all the requirements stated herein. The lowest bidder will be the bidder whose total bid price for all phases of work is lowest. The County will determine after receipt of bids which phase or phases will be included in the contract based on the bid amounts for each respective phase as submitted by the lowest bidder. Within **60** days after the time of opening the bids, County will act either to accept a proposal or to reject all proposals. The acceptance of a proposal will be evidenced by a notice of award of contract in writing, delivered in person or by mail to the bidder whose proposal is accepted. No other act of County shall constitute acceptance of a bid. The award of contract shall obligate the bidder whose bid is accepted to furnish a performance bond, payment bond and evidences of insurance (certificates of insurance and endorsements specified in the contract) and execute the agreement set forth in the contract documents.

County reserves the right to reject any and all bids and to waive any and all formalities, and the right to disregard all nonconforming, non-responsive, or conditional bids. County reserves the right to reject the bid of any bidder if County believes that it would not be in the best interest of the project to make an award to that bidder, whether because the bid is not responsive or the bidder is unqualified or of doubtful financial ability or fails to meet any other pertinent standard or criteria established by County. County reserves the right to reject any bids which omit a bid on any one or more items on which bids are required; any bids which omit unit prices if unit prices are required; any bids in which unit prices are unbalanced in the opinion of County; any bid accompanied by insufficient or irregular bid security; and any bids from bidders who have previously failed to perform properly or to complete on time contracts of any nature.

It is County's intent to accept alternates (if any are accepted) in the order in which they are listed in the bid form, but County may accept them in any order or combination.

County may consider the qualifications and experience of subcontractors and other persons and organizations (including those who are to furnish the principal items of material or equipment) proposed for those portions of the work as to which the identity of subcontractors and other persons and organizations must be submitted as provided herein. Operating costs, maintenance considerations, performance data and guarantees of materials and equipment may also be considered by County.

If there is reason to believe that collusion exists among the bidders, none of the bids of the participants in such collusion will be considered, and County may likewise elect to reject all bids received.

County may conduct such investigations as County deems necessary to assist in the evaluation of any bid and to establish the responsibility, qualifications and financial ability of the bidders, proposed subcontractors and other persons and organizations to do the work in accordance with the contract documents to County's satisfaction within the prescribed time. County reserves the right to reject the bid of any bidder who does not pass any such evaluation to County's satisfaction.

If the contract is to be awarded, it will be awarded to the lowest bidder whose evaluation by County indicates to County that the award will be in the best interests of the project.

#### **24. SIGNING OF AGREEMENT**

When County gives a Notice of Award to the successful bidder, it will be accompanied by unsigned counterparts of the agreement and all other contract documents.

**3** copies of the contract documents will be prepared by County. All copies will be submitted to Contractor, and Contractor shall execute the contract, insert executed copies of the required bonds and power of attorney, and submit all copies to County within **5** days. The date of execution of the contract shall be left blank for filling in by County.

**25. NOTICE TO PROCEED**

County shall give the successful bidder written notice to proceed with the work within 7 days of the execution of the contract. Notwithstanding any other provision of the contract, County shall not be obligated to accept or to pay for any work furnished by the Contractor prior to delivery of notice to proceed whether or not County has knowledge of the furnishing of such work.

**26. PERFORMANCE AND OTHER BONDS**

The contract documents set forth County's requirements as to performance and other bonds. When the successful bidder delivers the executed contract to County, it shall be accompanied by the required contract security. The bonds shall be provided on County's forms or on forms which are substantially similar. Notwithstanding any language contained in the bonds, County shall not be liable for attorney's fees either for the enforcement of the bond or for any other action under this Contract. Bonds shall not contain any date of termination.

**27. CONTRACTUAL RESTRICTIONS**

No official of County who is authorized in such capacity and on behalf of County to negotiate, make, accept or approve, or to take part in negotiating, making, accepting, or approving any architectural, engineering, inspecting, construction or material supply contract or any subcontract in connection with the construction of the project, shall become directly or indirectly interested personally in this contract or in any part thereof. No officer, employee, architect, attorney, engineer, or inspector of or for County who is authorized in such capacity and on behalf of County who is in any legislative, executive, supervisory, or other similar function in connection with the construction of the project, shall become directly or indirectly interested personally in this contract or in any part thereof, any material supply contract, subcontract, insurance contract, or any other contract pertaining to the project.

**28. POSTING SECURITY IN LIEU OF RETENTION**

The Contractor may elect to receive 100% of payments due under this contract from time to time, without retention of any portion of the payment by the public agency, by depositing securities of equivalent value with County in accordance with the provisions of Section 22300 of the California Public Contract Code; except that no such substitution shall be allowed where federal money is funding the project and federal regulations or policies would prohibit such substitution of securities for the retention. Securities eligible for investment shall include those listed in Section 16430 of the California Government Code, or bank or savings and loan certificates of deposits. Such securities, if deposited by the bidder, shall be valued by County whose decision on the valuation of the securities shall be final. The bidder shall be the beneficial owner of any securities substituted for money withheld and shall receive any interest thereon.

**29. LIQUIDATED DAMAGES**

The County is authorized by Government Code Section 53069.85 to assess liquidated damages for delay. County refers bidders to the Contract for review of the liquidated damages provision to be included in this Contract.

**CHECKLIST OF DOCUMENTS ENCLOSED BY BIDDER**

Bidder shall acknowledge that he or she has enclosed all required Bidding Documents listed herein by signing his or her initials in "Bidder" column, after each item.

DOCUMENT	SIGNATURES	
	BIDDER	COUNTY REP.
1. BID FORM (signed)		
2. ACKNOWLEDGMENT OF ADDENDA		
3. BID SECURITY: Bid Bond for bids over \$25,000 (must be signed by corporate surety); or Cashier's Check; or Certified Check; or Cash		
4. EXPERIENCE STATEMENT FORM		
5. SUBCONTRACTOR LISTING (signed)		
6. BIDDER'S REPRESENTATIONS: (BIDDER'S QUALIFICATIONS, NONCOLLUSION DECLARATION)		

**BID FORM**  
(Nevada County Standard Form Bid Document)

**BID TO THE COUNTY OF NEVADA FOR: Joseph Center Rear Entrance Improvements**

Name of Bidder \_\_\_\_\_

The work to be done and referred to herein is in Nevada County, State of California, and shall be constructed in accordance with the Plans, Specifications (including the payment of not less than the wages rates set forth therein) and the Contract annexed hereto.

The work to be done is shown upon project documents entitled: **Joseph Center Rear Entrance Improvements.**

The undersigned, as bidder, declares that the only persons or parties interested in this bid as principals are those named herein; that this bid is made without collusion with any other person, firm, or corporation, and in submitting this bid, the undersigned bidder agrees that he or she has carefully examined the location of the proposed work, the annexed proposed form of contract, and the plans therein referred to and all other documents listed or incorporated in the bidding documents and contract documents; and bidder proposes, and agrees if this bid is accepted, that bidder will contract with the County of Nevada in the form of the copy of the contract annexed hereto, to provide all necessary machinery, tools, apparatus, and other means of construction, and to do all the work and furnish all the materials specified in the contract, in the manner and time therein prescribed, and according to the requirements of County as therein set forth, and that bidder will take in full payment therefor the following:

<b>Item No.</b>	<b>Item</b>	<b>Unit of Measure</b>	<b>Total</b>
1.	Joseph Center Rear Entrance Improvements	Lump Sum	

Total of Bid (in figures): \_\_\_\_\_

Total of Bid (in words): \_\_\_\_\_

Alternate Bid Total (in figures): \_\_\_\_\_

Alternate Bid Total (in words): \_\_\_\_\_

The undersigned bidder agrees to furnish the required bonds or other security and to enter into a contract within the time specified in the Instructions to Bidders, and further agrees to complete all work covered by the bid, in accordance with all requirements of the contract.

Receipt of copies of the following addenda is hereby acknowledged.

<u>Addendum No.</u>	<u>Bidder's Signature</u>	<u>Date Acknowledged</u>
_____	_____	_____
_____	_____	_____

All addenda received have been considered in preparation of this bid.

Enclosed herewith are the Bid Form, Bid Bond or other security, Experience Statement, Subcontractor Listing and Bidder's Representations form.



In submitting this bid it is understood that the right is reserved by County to reject any and all bids, and it is understood that this bid may not be withdrawn during the period set forth in the Instructions to Bidders.

Envelopes containing bids must be marked as required by the Instructions to Bidders.

County reserves the right to reject any and all bids and to waive any irregularities in bids.

The amount of the bid for comparison purposes will be the total of all items. The total of unit basis items will be determined by extension of the item price bid on the basis of the estimated quantity set forth for the item.

Prices bid shall include overhead, profit and all applicable taxes.

By submission of this bid, each bidder certifies, and in the case of a joint bid each party thereto certifies as to its own organization, that this bid has been arrived at independently, without consultation, communication, or agreement as to any matter relating to this bid with any other bidder or with any competitor.

A bid bond for bids over \$25,000 will accompany this bid in a sum of not less than ten percent (10%) of the total amount of the bid and shall be on a form approved by County or a form which is substantially similar, which is attached hereto.

If this bid shall be accepted and the undersigned shall fail to contract as aforesaid, and to give the performance bond and labor and material bond as required in the contract with a surety satisfactory to County within the number of days set forth in the Instructions to Bidders after receipt of notice that the contract has been awarded to the undersigned, County may, at its option, determine that the bidder has abandoned the contract and thereupon the award of the contract shall be null and void and the bidder and surety shall forfeit the security accompanying this bid to the County of Nevada.

Accompanying this bid is: Circle one: Bidder's Bond -- Cashier's Check -- Certified Check -- Cash

for \$ \_\_\_\_\_, an amount equal to ten percent (10%) of the total bid.

The names of individuals who are principals in any partnership, joint venture, business association or corporation in the foregoing bid are as follows:

\_\_\_\_\_  
\_\_\_\_\_

Licensed in accordance with an act providing for the registration of contractors, License No. \_\_\_\_\_

DATED: \_\_\_\_\_  
Authorized Signature of Bidder

PRINTED NAME OF AUTHORIZED REPRESENTATIVE: \_\_\_\_\_

BUSINESS ADDRESS: \_\_\_\_\_

PLACE OF RESIDENCE: \_\_\_\_\_

TELEPHONE NUMBER: \_\_\_\_\_

EMAIL ADDRESS: \_\_\_\_\_

CLASSIFICATION OF CONTRACTOR'S LICENSE: \_\_\_\_\_

EXPIRATION DATE OF CONTRACTOR'S LICENSE: \_\_\_\_\_

DIR# \_\_\_\_\_ FEDERAL TAX ID. NO.: \_\_\_\_\_

**NOTE:** If bidder is a corporation, the legal name of the corporation shall be set forth above together with the signature of the officer or officers authorized to sign contracts on behalf of the corporation; if bidder is a co-partnership, the true name of the firm shall be set forth above together with the signature of the partner or partners authorized to sign contracts on behalf of the co-partnership; and if bidder is an individual, his or her signature shall be placed above. If a bidder is a joint venture, the documents must be signed by an authorized officer of each firm to the joint venture and shall include the California Contractor's License number of each partner to the joint venture. The signature of any attorney-in-fact must be notarized.

**BIDDER'S BOND**

STATE OF CALIFORNIA

COUNTY OF NEVADA

KNOW ALL PERSONS BY THESE PRESENT,

That we, \_\_\_\_\_ as principal, and \_\_\_\_\_ as surety, are held and firmly bound unto the County of Nevada in the sum of ten percent (10%) of the total amount of the bid of the principal above named, submitted by said principal to the County of Nevada for the work described below, for the payment of which sum in lawful money of the United States, well and truly to be made, to the County of Nevada, we bind ourselves, our heirs, executors, administrators, and successors, jointly and severally, firmly by these presents. In no case shall the liability of the surety hereunder exceed the sum of \$ \_\_\_\_\_

The condition of this obligation is such that whereas the principal has submitted the above-mentioned bid to the County of Nevada, as aforesaid, for certain construction specifically described as follows, for which bids are to be opened at Nevada City, California on \_\_\_\_\_, 20\_\_ for \_\_\_\_\_.

NOW, THEREFORE, if the aforesaid principal is awarded the contract, and within the time and manner required by the contract documents, after the prescribed forms are presented to him or her for signature, enters into a written Contract, in the prescribed form, in accordance with the bid, and files two bonds with the County of Nevada, one to guarantee faithful performance and the other to guarantee payment for labor and materials, as required by law, then this obligation shall be null and void; otherwise it shall be and remain in full force and effect.

Notice to Surety shall be provided at:

\_\_\_\_\_  
\_\_\_\_\_  
\_\_\_\_\_

IN WITNESS WHEREOF, we have hereunto set our hands and seals on this \_\_\_\_ day of \_\_\_\_\_, A.D. 20\_\_.

_____ Seal	_____ Seal
_____ Seal	_____ Seal
_____ Seal	_____ Seal
Principal	Surety

**NOTE:** Signature of Surety shall be notarized. Power of attorney for surety with corporate seal affixed must be attached.

APPROVED AS TO FORM  
BY COUNTY COUNSEL

\_\_\_\_\_



**LIST OF SUBCONTRACTORS**

NAME: \_\_\_\_\_

BUSINESS ADDRESS: \_\_\_\_\_

PHONE: \_\_\_\_\_

EMAIL: \_\_\_\_\_

DESCRIPTION OF WORK PERFORMED: \_\_\_\_\_

CONTRACTOR'S LICENSE # \_\_\_\_\_

DIR # \_\_\_\_\_

NAME: \_\_\_\_\_

BUSINESS ADDRESS: \_\_\_\_\_

PHONE: \_\_\_\_\_

EMAIL: \_\_\_\_\_

DESCRIPTION OF WORK PERFORMED: \_\_\_\_\_

CONTRACTOR'S LICENSE # \_\_\_\_\_

DIR # \_\_\_\_\_

NAME: \_\_\_\_\_

BUSINESS ADDRESS: \_\_\_\_\_

PHONE: \_\_\_\_\_

EMAIL: \_\_\_\_\_

DESCRIPTION OF WORK PERFORMED: \_\_\_\_\_

CONTRACTOR'S LICENSE # \_\_\_\_\_

DIR # \_\_\_\_\_

\_\_\_\_\_  
SIGNATURE OF  
CONTRACTOR

IF MORE SUBCONTRACTORS ARE LISTED PLEASE ADD AN  
ADDITIONAL PAGE

**BIDDER'S REPRESENTATIONS**

I, the undersigned, declare as follows:

- 1. BIDDER'S QUALIFICATIONS: That neither I nor a company of which I am more than 50% owner have been disqualified from bidding, removed from a public works construction project or otherwise been prevented from bidding because of a violation of law or a safety regulation.

Further, I declare under penalty of perjury that neither I nor a company of which I am more than a 50% owner have had more than one final, unappealable finding of contempt of court by a Federal court within the immediately preceding two year period because of failure to comply with an order of the Federal court (Public Contract Code Section 10232), which orders the Contractor to comply with an order of the National Labor Relations Board.

Further, I declare under penalty of perjury that I have not been convicted by any court of any charge of fraud, bribery, collusion, conspiracy, or any other act in violation of state or federal antitrust law in connection with the bidding upon, award of, or performance of any public works contract.

- 2. WORKER'S COMPENSATION CERTIFICATION (LABOR CODE SECTION 1861): That I am aware of the provisions of Section 3700 of the Labor Code of the State of California, which requires every employer to be insured against liability for Worker's Compensation or to undertake self-insurance in accordance with the provisions of that Code, and I will comply with such provisions before commencing the performance of the work of this Contract.

- 3. NONCOLLUSION DECLARATION: I, the undersigned, declare that I am the \_\_\_\_\_ of \_\_\_\_\_ the party making the foregoing bid that the bid is not made in the interest of, or on behalf of, any undisclosed person, partnership, company, association, organization, or corporation; that the bid is genuine and not collusive or sham; that the bidder has not directly or indirectly induced or solicited any other bidder to put in a false or sham bid, and has not directly or indirectly colluded, conspired, connived, or agreed with any bidder or anyone else to put in a sham bid, or that anyone shall refrain from bidding; that the bidder has not in any manner, directly or indirectly, sought by agreement, communication, or conference with anyone to fix the bid price of the bidder or any other bidder, or to fix any overhead, profit, or cost element of the bid price, or of that of any other bidder, or to secure any advantage against the public body awarding the contract of anyone interested in the proposed contract; that all statements contained in the bid are true; and, further, that the bidder has not, directly or indirectly, submitted his or her bid price or any breakdown thereof, or the contents thereof, or divulged information or data relative thereto, or paid, and will not pay, any fee to any corporation, partnership, company association, organization, bid depository, or to any member or agent thereof to effectuate a collusive or sham bid.

I declare under penalty of perjury under the laws of the State of California that the foregoing is true and correct.

DATED: \_\_\_\_\_

BIDDER: \_\_\_\_\_

**PUBLIC WORKS CONTRACT—SHORT FORM [\$4,000-\$49,999]  
County of Nevada, California**

This Public Works Contract is made between the **COUNTY OF NEVADA** (herein "County") and

**Contractor's Name**

(herein "Contractor"), for the following Project:

(§1) **Joseph Center Rear Entrance Improvements**

and incorporates herein by reference Contractor's bid to perform said Project dated \_\_\_\_\_.

**SUMMARY OF SELECTED TERMS**

- (§2) Contract Price: \$ \_\_\_\_\_
- (§3) Time of Completion 60 days after mailing or delivery of Notice to Proceed
- (§4) Liquidated Damages \$ 150 per day of delay (see Section 4 of contract)

**BONDS AND INSURANCE**

	Required	Not required
<b>(§5) Bonds:</b>		
(a) Faithful Performance Bond	_____	✓ _____
(b) Labor and Materials Bond	_____	✓ _____
(c) Retention Bond	_____	✓ _____
<b>(§6) Insurance Policies:</b>		
(a) Commercial General Liability (\$1 million)	✓ _____	_____
(b) Personal Auto Liability (\$ 300,000)	_____	✓ _____
Business Rated Auto Liability (\$1 million)	✓ _____	_____
Commercial Auto Liability (\$1 million)	_____	✓ _____
(c) Workers' Compensation	✓ _____	_____
(d) Errors and Omissions (\$1 million)	_____	✓ _____

(§24) **Contractor:**

**County of Nevada:**  
**Facilities Management**  
 10014 N. Bloomfield  
 Nevada City, CA 95959  
 Contact Person: Tim Horner  
 (530) 265-1406  
 e-mail: tim.horner@co.nevada.ca.us  
 Org Code/PCN:

Contact Person:  
 ( )  
 e-mail:  
 Fed Tax ID:

**Contractor Status** (check all that apply):

Corporation: \_\_\_\_\_ Calif. \_\_\_\_\_ Other \_\_\_\_\_ LLC \_\_\_\_\_ Nonprofit  
 Partnership: \_\_\_\_\_ Calif. \_\_\_\_\_ Other \_\_\_\_\_ LLP \_\_\_\_\_ Limited  
 Person: \_\_\_\_\_ Individual \_\_\_\_\_ DbA \_\_\_\_\_ Ass'n \_\_\_\_\_ Other

**ATTACHMENTS**

Designate all required attachments:

	Req'd	Not Req'd
<b>Exhibit A: PCC Secs. 20104.2 &amp; 20104.4</b>	✓ _____	_____
<b>Exhibit B: Scope of Work</b>	✓ _____	_____
<b>Exhibit C: Schedule of Changes to this Contract Form</b>	_____	✓ _____

## Terms

Each term of this Contract below specifically incorporates the information set forth in the Summary at page one (1) above as to each respective section (§) therein, as the case may be.

1. **SCOPE OF WORK; CONTRACT DOCUMENTS; SUCCESSORS:** The Contractor shall do the work for the Project and provide materials as shown in Exhibit B attached hereto. The contract documents include this contract, any general and special conditions, plans and specifications, bidding documents, addenda, and proposals submitted by Contractor. Any inconsistencies between the documents shall be resolved by according the highest priority to this Contract, any special provisions or conditions, and the standard specifications. The contract documents may only be amended by written mutual consent or by written change order. The parties bind their successors in interest to every covenant and obligation in the contract documents.

2. **CONTRACT PRICE AND PAYMENTS:** The contract price is specified at §2 on page one (1).

Contractor may apply for progress payments on a monthly basis. Contractor shall submit a signed invoice covering the work completed to that date, and accompanied by supporting documentation to the County's satisfaction. Progress payments will be in an amount equal to 95 percent (95%) of the work completed. Contractor may substitute securities for any retention as set forth in PCC Sec. 22300.

Pursuant to PCC Sec. 20104.50, each payment request shall be reviewed by County as soon as practicable after receipt. Any request not suitable for payment shall be returned promptly, and in no event later than seven calendar days from its date of receipt. A request that is returned unpaid shall be accompanied by a written explanation by the County. The number of days available by the County to make a payment without incurring interest pursuant to PCC Sec. 20104.50 shall be reduced by the number of days by which the County exceeds the seven day return requirement.

Payment of any retention for the completed project will not be due until at least 35 days after the recording of the Notice of Completion, or no later than 60 days after completion of the Project as defined in PCC Sec. 7107, whichever occurs first. Payment may be made earlier if the County receives from each and every subcontractor and supplier an 'Unconditional Waiver and Release Upon Final Payment' in the form prescribed by Civil Code Section 3262(d). Acceptance of final payment will be deemed a waiver of all claims except those which were timely made pursuant to claims and civil action procedures described in Exhibit A.

Invoices, or other applications for County payment, shall contain detailed full documentation of all work performed and all reimbursable expenses incurred. Where the Scope of Work is divided into tasks, invoices shall detail the related expenditures accordingly. No expense will be reimbursed without documentation.

3. **CONTRACT TIME:** Contractor shall commence work within ten (10) days after mailing or personal delivery by County of a written Notice to Proceed. All work shall be completed for acceptance on or before the number of days following the mailing or delivery of the Notice to Proceed indicated on page one (1). After issuance of the Notice to Proceed, the County may, at any time and without cause, suspend the Project work, or any portion of it, for a reasonable period of time by giving at least 72 hours advance written notice to the Contractor.

Time is of the essence. If the work is not timely completed, subject to such extensions as the County may grant for unavoidable delay, the Contractor may be assessed damages for delay in accordance with the liquidated damages clause below. The County reserves sole discretion to determine issues of delay. Any liquidated damages may be deducted as an off-set against any amounts due to the Contractor.

4. **LIQUIDATED DAMAGES:** County and Contractor acknowledge that the County will suffer financial loss if the Project is not completed within the time specified. They also acknowledge the difficulty of ascertaining with specificity the exact amount of such loss. Instead of requiring proof with specificity, the parties agree that the amount of liquidated damages shall be the amount shown on page one,



payable to County for each day that expires after the time specified for completion on page one. Liquidated damages shall be payable by Contractor only if the delay results from the failure of Contractor to perform timely, and not because of delays occasioned by the County, State, or any federal agency.

5. **BONDS:** All bonds required under this Contract shall be issued by a corporation duly licensed to transact surety business in California. The bond must be executed by proper corporate signatories, and adequate proof of their authority to act and bind the surety must be provided to the County.

#### REQUIRED BONDS (CONFORMS TO §5 ON PAGE 1)

- (a) A Faithful Performance Bond is required if this Contract's price exceeds \$25,000 in order to ensure completion of the Project, per this Contract, in the amount of 100% of the Contract price; it shall remain in effect during the warranty period on any work or equipment.
- (b) A Labor and Materials Bond is required if this Contract's price exceeds \$25,000 in order to ensure proper payment to all persons so entitled because of supplying materials and labor; it shall remain in effect until the expiration of 35 days after recording of the Notice of Completion.
- (c) A Retention Bond may be required in order to ensure that funds remain available after completion of the Project in lieu of a cash retention; the County's election in this regard is shown on page one.

#### 6. **LIABILITY INSURANCE; WORKERS' COMPENSATION INSURANCE:**

##### GENERAL REQUIREMENTS FOR INSURANCE

All policies of insurance required by this Contract shall remain in full force and effect throughout the life of this Contract. The insurance shall have a provision that 30 days advance written notice will be given to the County before any termination or change in coverage protection, or reduction in coverage limits (except 10 days notice for non-payment of premium).

Failure to provide and maintain the insurance policies, endorsements, or certificates of insurance required by this Section shall constitute a material breach of this Contract and serve as a basis for the County to suspend payments or terminate this Contract. The contractor also shall cause and require each subcontractor, or any assignee, to comply with the requirements of this Section.

##### ADDITIONAL REQUIREMENTS FOR LIABILITY INSURANCE

Liability insurance shall be payable on a "per occurrence" basis unless the County specifically consents to "claims made" coverage. If the County does consent to "claims made" coverage, and if Contractor changes insurance carriers during the term of the Contract, or during any extensions, then Contractor shall carry "prior acts" coverage.

Liability insurance, including both commercial general liability insurance and automobile liability insurance, shall have an endorsement naming the County of Nevada and its officers, agents, employees and volunteers as additionally insured, and in the event of insured loss the Contractor's liability insurance shall apply as primary insurance, and other insurance maintained by the County shall be excess only and not contributing with Contractor's insurance. The additional insured endorsement shall be evidenced by form CG 20 10 11 85 or equivalent, subject to approval by the County's Risk Manager.

At all times, the Contractor shall maintain policies issued by companies with an Best's Rating of B+ or higher, or a Best's Financial Performance Rating of 6 or higher, according to the current A.M. Best's Key Rating Guide, or shall be issued by companies approved by the County's Risk Manager. In the event the Best's Rating or Best's FPR falls below the rating required by this Section, then the Contractor shall promptly secure policies which do comply with this Section.

REQUIRED INSURANCE (CONFORMS TO §6 ON PAGE 1)

- (a) As indicated on page one, the Contractor shall promptly provide proof of broad form coverage for Commercial General Liability Insurance with a combined single limit of not less than one million dollars (\$1,000,000).
- (b) At County's option, as indicated on page one, the Contractor shall promptly provide proof of coverage for Personal, Business Rated, or Commercial Auto Liability Insurance for each vehicle used, including non-owned and hired automobiles. The coverage shall be combined single limit and shall include death, bodily injury, property damage, and uninsured and underinsured coverage, in the amount shown on page one.
- (c) As indicated on page one, the Contractor shall provide proof of adequate Worker's Compensation Insurance, as required by law. Contractor hereby certifies that it is aware of the California Labor Code (Section 3700 *et seq.*) requirement that every employer be insured before commencing work, and that every contractor require this insurance as to all of its subcontractors before they commence work.
- (d) At County's option, as indicated on page one, the Contractor shall promptly provide proof of coverage for Professional Liability Insurance, or "an errors and omissions" policy, in the amount shown on page one (1).

7. **RISK OF LOSS; INDEMNIFICATION:** Loss or damage to equipment, materials, or services, occurring on or off the work site, shall be the responsibility of the Contractor. The County shall not assume liability for completed work until the County has accepted the work as complete.

The contractor shall indemnify, hold harmless, and defend the County and its consultants, agents, officers, employees, and volunteers from and against all claims, damages, losses, and attorneys fees, and related expenses, whether direct or indirect, arising out of the negligent actions or willful misconduct of the Contractor, or its agents, except to the extent caused by the negligence or misconduct of the County or its agents or employees.

8. **ASSIGNMENT:** No assignment or transfer of obligation relating to this Contract shall be valid unless it is approved in advance in writing by both parties.

9. **CHANGES IN THE WORK:** The County may order additions, deletions, or revisions in the Project which shall be authorized by written change order. Prior to doing any additional work that the Contractor finds necessary, such change shall be reduced to writing as a written change order request to be approved by the County before the additional work is undertaken. Changes in contract price due to change orders shall be established by any of the following: (1) unit prices, where bidding was done by unit price; (2) the actual cost of work plus 15% for overhead and profit together; or (3) by mutual acceptance of a lump sum.

10. **MATERIALS AND EQUIPMENT FOR INSTALLATION:** All material and equipment installed shall be of good quality, and new, unless this Contract provides otherwise. Whenever materials or equipment are specified or described in the Contract Documents by using the name of a proprietary item or a particular supplier, it is intended to establish the type, function, and quality required. Any substitutions require the County's express consent prior to use or installation. All of the manufacturer's operating and maintenance instructions shall be delivered to the County prior to Contractor's receipt of final payment.

11. **WARRANTY AND CORRECTION PERIOD:** If any work or installation is defective within one year after the date of completion of the Project, or such longer period of time as may apply by reason of special guarantees or legal regulations, the Contractor shall either correct such work or replace it with non-defective work, at no cost to the County. If the Contractor does not correct or replace the work in a prompt manner, then the County may elect to have the work corrected or replaced at the sole expense of the Contractor. "Defective" means a sub-standard or inferior product, whether from the quality or quantity of the materials used, the quality of workmanship, or the performance of the Contract.

12. **PERMITS AND TAXES:** Unless otherwise provided in the Contract Documents, the Contractor shall obtain, and pay for, all construction permits, licenses or other permits necessary to complete the Project, and shall be responsible for all governmental charges, inspection fees, utility connection charges, and sales and use taxes.
13. **PAYROLL RECORDS:** The Contractor shall be responsible for keeping accurate payroll records as required by California Labor Code Section 1776. Pursuant to Section 1776 (g) and (h), notice is given that the Contractor may be assessed a penalty of \$25 per worker if a certified copy of such records is not made available within 10 days of request.
14. **PREVAILING WAGE RATES:** Performance of this Contract shall be in conformity with the provisions of California Labor Code, Division 2, Part 7, Chapter 1, commencing with Section 1720 relating to prevailing wages which must be paid to workers employed on a public work as defined in Labor Code §§1720, et seq.; and shall be in conformity with Title 8 of the California Code of Regulations §§200 et seq., relating to apprenticeship. Contractor shall comply with the provisions thereof at the commencement of Services to be provided herein, and thereafter during the term of this Contract. A breach of the requirements of this section shall be deemed a material breach of this contract.

Applicable prevailing wage determinations are available on the California Department of Industrial Relations website at <http://www.dir.ca.gov/OPRL/PWD>. The Contractor shall post a copy of the wage rates on the job site. Any employee whose type of work is not covered by any of the classified wage rates shall be paid not less than the rate of wage listed for the classification which most nearly corresponds to the type of work to be performed.

Contractor and all subcontractors must comply with the requirements of Labor Code Section 1771.1(a) pertaining to registration of contractors pursuant to Section 1725.5. Registration and all related requirements of those Sections must be maintained throughout the performance of the Contract.

Contracts to which these prevailing wage requirements apply are subject to compliance monitoring and enforcement by the Department of Industrial Relations. Each contractor and subcontractor must furnish certified payroll records to the Labor Commissioner at least monthly.

The County is required to provide notice to the Department of Industrial Relations of any public work contract subject to prevailing wages within five (5) days of award.

Pursuant to California Labor Code Section 1775, the Contractor shall forfeit no more than \$50 per calendar day, or portion of a day, for each worker paid less than the prevailing rates for such work or craft, and the penalty shall be imposed and distributed pursuant to Section 1775.

15. **NON-DISCRIMINATION:** While this Contract is in effect, the Contractor shall comply with all provisions of California Labor Code Section 1735, as amended, regarding non-discrimination practices and equal employment opportunity.
16. **BOOKS OF RECORD AND AUDIT:** The Contractor shall maintain on a current basis complete books and records relating to this Contract, including but not limited to: (a) all income and all expenditures; (b) an itemization of all debits and credits for the work on this Project; (c) canceled checks, receipts and invoices; and (d) travel and field expenses. These records shall be maintained for five years following completion of the Project.

The Contractor will permit the County to audit all these books and records at the Contractor's premises. Alternatively, at the County's option, the Contractor will bring all books and records within 15 days to a location designated by the County in a written notice to that effect.

The Contractor shall refund any moneys erroneously charged. If the County ascertains an erroneous billing equal to 5% or more of the original bid, the Contractor shall be liable for the costs of the audit in addition to any other legal consequences.

17. **PRIOR NEVADA COUNTY EMPLOYMENT:** Pursuant to County Resolution No. 03-353, notice is given of the prohibition against certain former officials receiving direct remuneration from any legal entity that entered a contract or grant agreement with the County during the official's last twelve (12) months in office. The officials include former members of the Board of Supervisors, a former CEO, or a former Purchasing Agent.
18. **TERMINATION:** The County reserves the right to terminate this Contract based on the following:
- (a) The Contractor becomes a party in U.S. Bankruptcy Court because of a voluntary petition or a petition filed by creditors.
  - (b) The Contractor makes a general assignment for the benefit of creditors.
  - (c) If a trustee, receiver, or custodian of assets is appointed to take charge of the property of the Contractor for the purpose of enforcing a lien or administration of such property for the benefit of creditors.
  - (d) If the Contractor declares or admits that it is unable to pay its debts generally as they become due.
  - (e) If the Contractor persistently fails to perform the work of the Project in accordance with the Contract Documents, or substantially disregards the Documents.
  - (f) If the Contractor disregards any relevant laws or regulations, whether they are federal, state, or local.
  - (g) If the Contractor disregards the reasonable directions of the County's supervisory staff, including the Contract Administrator.

The County may terminate this Contract after giving seven days advance written notice to the Contractor. After termination is effective, the County may take sole possession of the work site and have the work finished with materials and equipment stored on or off the site. As time is of the essence, the County is not obligated to obtain the lowest price for the work performed. If the unpaid balance owing to the Contractor is less than the County's cost of finishing, then the County will demand payment of the difference from the Contractor. The Contractor shall not be entitled to any payment until the work is finished. The County's implementation of this Section shall not waive or be deemed to prejudice any other rights or remedies to which the County is entitled.

19. **CONTRACT ADMINISTRATION:** The County may designate staff, or hire professional services, as "Contract Administrator" for Project supervision and administration. The Contract Administrator is delegated authority to determine the amount, quality, acceptability and fitness of the work, materials, and equipment to be paid under this Contract, to decide all questions relative to Contract interpretation, to reject all work or material which does not conform to the terms of this Contract, and to make a final determination on all claims submitted to the County.

If there is an apparent ambiguity in the Contract Documents, the Contractor shall request a written interpretation from the Contract Administrator. If the Contractor believes that an interpretation justifies an increase in the Contract Price, or an extension of the Contract Time, and the parties are unable to agree on the amount or extent, then the Contractor may make a claim.

The Contract Administrator may, only in writing, authorize or require variations in the work from what is shown in the Contract Documents. If the Contractor and the County cannot agree on a change order amount or extension of time, the Contractor may make a claim. If the Contract was based on unit pricing, the Contract Administrator will determine the actual quantities and classifications of unit price work.

The Contract Administrator's written decisions will be final and binding on the Contractor unless the Contractor timely delivers a written notice, in the form of a claim with supporting facts and reasons, that the Contractor disputes the decision.

For every claim that the Contractor makes, it shall provide adequate documentation for consideration of the claim. This documentation shall be supplemented at the request of the County, and may include bidding calculations, forms, cost estimates, time sheets, trend reports, job cost analysis records, labor records, as-built documents, or any other relevant documents from the bidding and construction. Further, the County may conduct an audit of all relevant books and records, particularly relating to overhead, profit, or general office expenses charged to the Project.

20. **CLAIMS RESOLUTION AND CIVIL ACTION PROCEDURES:** California Public Contract Code (PCC) Sec. 20104 – 20104.6 govern all public works claims of \$375,000 or less which arise between a contractor and a local agency. In PCC Sec. 20104(b)(2) it is stated that “Claim” means a separate demand by the contractor for (a) a time extension; (b) payment of money or damages arising from work done by, or on behalf of, the contractor pursuant to the contract for a public work, and payment of which is not otherwise expressly provided for or the claimant is not otherwise entitled to; or (c) an amount the payment of which is disputed by the local agency. Exhibit A of this Contract contains copies of the following: Claims Resolution Procedures are set forth in PCC Sec. 20104.2, and Civil Action Procedures are set forth in PCC Sec. 20104.4.
21. **NO WAIVER OF RIGHTS BY COUNTY:** No waiver of any right or remedy belonging to the County shall be deemed to have occurred because of any action or inaction by the County in its performance of this Contract.
22. **SEVERABILITY; COUNTERPARTS:** If any provision of this Contract is found by a court to be unenforceable or void, then both parties shall be relieved of all obligations arising from the provision, and the remainder of this Contract shall continue in full force and effect.  
  
This Contract may be executed in counterparts, and each counterpart shall be deemed an original instrument.
23. **JURISDICTION AND VENUE:** This Contract shall be construed in accordance with the laws of the State of California, and the venue for any litigation arising under this Contract shall be Nevada County Superior Court, or if federal issues are involved, in the U.S. District Court - Eastern District of California (Sacramento Division).
24. **NOTICES:** Any notices from one party to the other with respect to important matters related to this Contract shall be mailed, faxed, e-mailed, or delivered as shown on page one (1).

**EXECUTION:** The signatures below indicate acceptance of, and execution of, this Contract, as of the date when execution has been completed by both parties.

**CONTRACTOR:**

\_\_\_\_\_  
Name:  
Title:

\_\_\_\_\_  
Contractor's License Number

Dated: \_\_\_\_\_

**COUNTY OF NEVADA:**

\_\_\_\_\_  
Honorable Dan Miller  
Chair, Board of Supervisors

Dated: \_\_\_\_\_

Attest: \_\_\_\_\_  
Julie Patterson Hunter  
Clerk of the Board

**EXHIBIT "A"**  
COPY OF PUBLIC CONTRACT CODE SECTIONS ON CLAIMS RESOLUTION PROCEDURES  
AND CIVIL ACTION PROCEDURES  
(as of December 4, 2007)

**20104.2 Claims; requirements; tort claims excluded**

20104.2. For any claim subject to this article, the following requirements apply:

(a) The claim shall be in writing and include the documents necessary to substantiate the claim. Claims must be filed on or before the date of final payment. Nothing in this subdivision is intended to extend the time limit or supersede notice requirements otherwise provided by contract for the filing of claims.

(b) (1) For claims of less than fifty thousand dollars (\$50,000), the local agency shall respond in writing to any written claim within 45 days of receipt of the claim, or may request, in writing, within 30 days of receipt of the claim, any additional documentation supporting the claim or relating to defenses to the claim the local agency may have against the claimant.

(2) If additional information is thereafter required, it shall be requested and provided pursuant to this subdivision, upon mutual agreement of the local agency and the claimant.

(3) The local agency's written response to the claim, as further documented, shall be submitted to the claimant within 15 days after receipt of the further documentation or within a period of time no greater than that taken by the claimant in producing the additional information, whichever is greater.

(c) (1) For claims of over fifty thousand dollars (\$50,000) and less than or equal to three hundred seventy-five thousand dollars (\$375,000), the local agency shall respond in writing to all written claims within 60 days of receipt of the claim, or may request, in writing, within 30 days of receipt of the claim, any additional documentation supporting the claim or relating to defenses to the claim the local agency may have against the claimant.

(2) If additional information is thereafter required, it shall be requested and provided pursuant to this subdivision, upon mutual agreement of the local agency and the claimant.

(3) The local agency's written response to the claim, as further documented, shall be submitted to the claimant within 30 days after receipt of the further documentation, or within a period of time no greater than that taken by the claimant in producing the additional information or requested documentation, whichever is greater.

(d) If the claimant disputes the local agency's written response, or the local agency fails to respond within the time prescribed, the claimant may so notify the local agency, in writing, either within 15 days of receipt of the local agency's response or within 15 days of the local agency's failure to respond within the time prescribed, respectively, and demand an informal conference to meet and confer for settlement of the issues in dispute. Upon a demand, the local agency shall schedule a meet and confer conference within 30 days for settlement of the dispute.

(e) Following the meet and confer conference, if the claim or any portion remains in dispute, the claimant may file a claim as provided in Chapter 1 (commencing with Section 900) and Chapter 2 (commencing with Section 910) of Part 3 of Division 3.6 of Title 1 of the Government Code. For purposes of those provisions, the running of the period of time within which a claim must be filed shall be tolled from the time the claimant submits his or her written claim pursuant to subdivision (a) until the time that claim is denied as a result of the meet and confer process, including any period of time utilized by the meet and confer process.

(f) This article does not apply to tort claims and nothing in this article is intended nor shall be construed to change the time periods for filing tort claims or actions specified by Chapter 1 (commencing with Section 900) and Chapter 2 (commencing with Section 910) of Part 3 of Division 3.6 of Title 1 of the Government Code.

#### **20104.4 Civil Action Procedures; mediation and arbitration; trial de novo; witnesses**

20104.4. The following procedures are established for all civil actions filed to resolve claims subject to this article:

(a) Within 60 days, but no earlier than 30 days, following the filing or responsive pleadings, the court shall submit the matter to nonbinding mediation unless waived by mutual stipulation of both parties. The mediation process shall provide for the selection within 15 days by both parties of a disinterested third person as mediator, shall be commenced within 30 days of the submittal, and shall be concluded within 15 days from the commencement of the mediation unless a time requirement is extended upon a good cause showing to the court or by stipulation of both parties. If the parties fail to select a mediator within the 15-day period, any party may petition the court to appoint the mediator.

(b) (1) If the matter remains in dispute, the case shall be submitted to judicial arbitration pursuant to Chapter 2.5 (commencing with Section 1141.10) of Title 3 of Part 3 of the Code of Civil Procedure, notwithstanding Section 1141.11 of that code. The Civil Discovery Act (Title 4 [commencing with Section 2016.010] of Part 4 of the Code of Civil Procedure) shall apply to any proceeding brought under this subdivision consistent with the rules pertaining to judicial arbitration.

(2) Notwithstanding any other provision of law, upon stipulation of the parties, arbitrators appointed for purposes of this article shall be experienced in construction law, and, upon stipulation of the parties, mediators and arbitrators shall be paid necessary and reasonable hourly rates of pay not to exceed their customary rate, and such fees and expenses shall be paid equally by the parties, except in the case of arbitration where the arbitrator, for good cause, determines a different division. In no event shall these fees or expenses be paid by state or county funds.

(3) In addition to Chapter 2.5 (commencing with Section 1141.10) of Title 3 of Part 3 of the Code of Civil Procedure, any party who after receiving an arbitration award requests a trial de novo but does not obtain a more favorable judgment shall, in addition to payment of costs and fees under that chapter, pay the attorney's fees of the other party arising out of the trial de novo.

(c) The court may, upon request by any party, order any witnesses to participate in the mediation or arbitration process.



**EXHIBIT "B"**  
**SCOPE OF WORK**

**EXHIBIT "C"**

**SCHEDULE OF CHANGES**

(Amendments and Additions to Contract)

# JOSEPH GOV'T CENTER ANNEX

## EMPLOYEE ENTRANCE REPAIRS

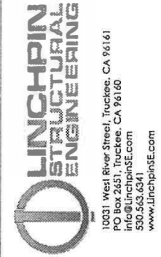

### REVISIONS

NO.	DESCRIPTION	DATE
1	ISSUED	02/20/20

These drawings have been prepared by Linchpin Structural Engineering Inc. They are not suitable for use on other projects, in other locations, or by any other individuals without the written approval and signature of Linchpin Structural Engineering Inc. Reproduction is prohibited.

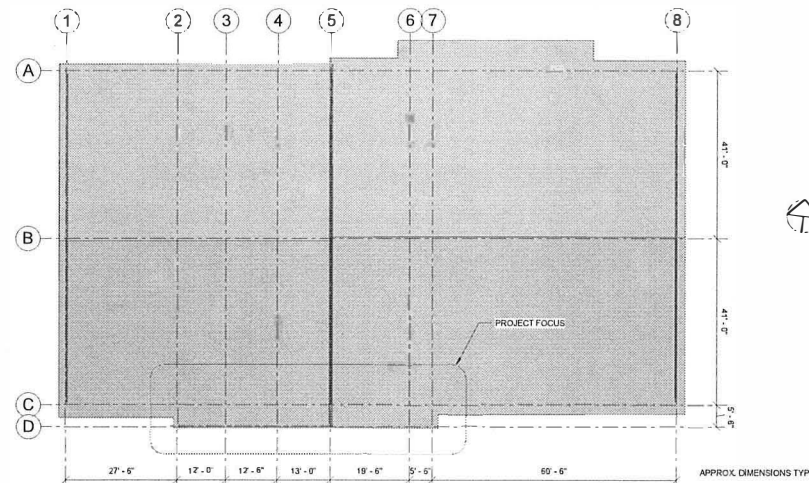

BUILDING LAYOUT  
1/16" = 1'-0"

**JOSEPH GOV'T CENTER ANNEX**  
10075 LEVON RD  
TRUCKEE, CA - 96161

### GENERAL NOTES

- UNLESS EXPLICITLY STATED IN THESE CONSTRUCTION DOCUMENTS, BY NOTE OR IDENTIFICATION LETTER, THE ENTIRE SCOPE OF WORK REPRESENTED BY THESE DOCUMENTS SHALL BE THE SOLE RESPONSIBILITY OF THE GENERAL CONTRACTOR.
- THESE CONSTRUCTION DOCUMENTS REPRESENT THE DESIGN INTENT OF THE DESIGN TEAM BASED ON DIMENSIONS OF EXISTING SITE AND/OR FIELD CONDITIONS. ACTUAL CONDITIONS MAY REQUIRE MODIFICATIONS OF THE CONSTRUCTION DETAILS TO ACHIEVE THE DESIGN INTENT. CONTRACTOR SHALL NOTIFY DESIGN TEAM IN WRITING OF ANY DISCREPANCIES RELATED TO EXISTING SITE AND/OR FIELD CONDITIONS PRIOR TO COMMENCING ANY WORK.
- IT IS THE RESPONSIBILITY OF THE CONTRACTOR TO RECORD ALL OMISSIONS OR CONFLICTS BETWEEN THE VARIOUS ELEMENTS OF THE CONSTRUCTION DOCUMENTS AND TO BRING THEM TO THE ATTENTION OF THE DESIGN TEAM PRIOR TO COMMENCING ANY WORK. ANY DEVIATION FROM THE CONDITIONS SHOWN IN THESE CONSTRUCTION DOCUMENTS SHALL REQUIRE WRITTEN APPROVAL FROM THE DESIGN TEAM.
- DO NOT SCALE THE DRAWINGS. WRITTEN DIMENSIONS SHALL TAKE PRECEDENCE OVER SCALED DIMENSIONS. ANY DISCREPANCIES BETWEEN THE DRAWINGS AND ACTUAL CONDITIONS SHALL BE BROUGHT TO THE ATTENTION OF THE DESIGN TEAM PRIOR TO COMMENCING ANY WORK.
- THE CONTRACT DOCUMENTS ARE COMPLEMENTARY WORK REQUIRED TO BE DONE BY ONE DOCUMENT AND NOT BY OTHERS SHALL BE DONE AS IF REQUIRED BY ALL.
- THE CONTRACTOR AND SUBCONTRACTOR SHALL MAKE NO STRUCTURAL SUBSTITUTIONS, CHANGES, OR MODIFICATIONS WITHOUT WRITTEN APPROVAL OF THE STRUCTURAL ENGINEER.
- CONTRACTORS AND SUBCONTRACTORS SHALL ENSURE THAT ALL WORK IS PERFORMED IN A PROFESSIONAL AND WORKMAN LIKE MANNER BY SKILLED MECHANICS OF THE TRADE. SUBCONTRACTORS AND SUPPLIERS ARE HEREBY NOTIFIED THAT THEY ARE TO COOPERATE AND COOPERATE FULLY WITH EACH OTHER DURING THE COURSE OF CONSTRUCTION TO DETERMINE THE EXACT EXTENT AND OVERLAP OF EACH OTHER'S WORK AND TO SUCCESSFULLY COMPLETE THE EXECUTION OF THE WORK IN A TIMELY MANNER.
- BUILDER'S SET: THIS SET OF DRAWINGS HAS BEEN PREPARED SUFFICIENT TO OBTAIN A BUILDING PERMIT. ALL MATERIALS AND METHODS OF CONSTRUCTION NECESSARY TO COMPLETE THE PROJECT ARE NOT NECESSARILY DESCRIBED IN THIS 'BUILDER'S SET'. THE IMPLEMENTATION OF THE DRAWINGS REQUIRES THE CONTRACTOR TO BE THOROUGHLY KNOWLEDGEABLE WITH THE APPLICATIONS OF CODES AND THE METHODS OF CONSTRUCTION SPECIFIC TO THIS PROJECT AND TYPE OF CONSTRUCTION.
- UNLESS SPECIFICALLY SHOWN OR NOTED ON THE DRAWINGS, NO STRUCTURAL MEMBER SHALL BE CUT, NOTCHED, BORED, OR OTHERWISE WEAKENED WITHOUT THE PERMISSION OF THE STRUCTURAL ENGINEER.
- ALL WATERPROOFING, FLASHING, AND DRAINAGE ARE TO BE DESIGNED AND PROVIDED BY THE BUILDER.

### VICINITY MAP

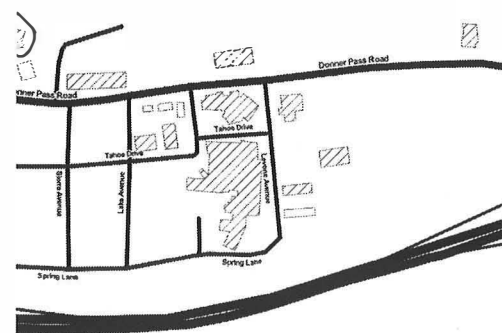

### PROJECT INFORMATION

**PROJECT ENGINEER**  
DOUGLAS GADGW  
LINCHPIN STRUCTURAL ENGINEERING  
530.582.7820 EXT. 1

**CLIENT**  
NEVADA COUNTY FACILITIES MAINTENANCE  
18014 W BLOOMFIELD RD  
NEVADA CITY, CA

**CONTRACTOR**  
TBD

### PROJECT SUMMARY

THE PROJECT IS A REPAIR OF AN EXISTING BUILDING FOR NEVADA COUNTY. A SPLITTER AND BEAM WILL BE REMOVED AND REPLACED WITH AN NEW BEAM. ADEQUATE WATERPROOFING AND A REDESIGN OF CEILING SYSTEM. EXISTING POSTS SHALL BE REPLACED TO REST ON NEW EXPOSED FOOTINGS TO AVOID DETERIORATION. NEW STEPS AND HANDRAILS WILL REPLACE THE EXISTING RAMP.

### APPLICABLE CODES

2013 CALIFORNIA BUILDING CODE (2013 CBC)  
2012 NATIONAL DESIGN STANDARD (2012 NDS)  
STEEL CONSTRUCTION MANUAL, 14 ED. (AISC 14 ED.)

### SHEET INDEX

Sheet Number	Sheet Name
S-000	COVER PAGE
S-001	SPECIFICATIONS
S-100	FOUNDATION & ROOF FRAMING PLAN
S-400	DETAILS

### GOVERNING AGENCY

TOWN OF TRUCKEE BUILDING DIVISION  
10143 TRUCKEE AIRPORT RD  
TRUCKEE, CA 95161  
530.582.7820 EXT 1

DESIGNED BY BB  
DRAFTED BY BB

CLIENT INFORMATION  
NEVADA COUNTY  
CONTACT ADDRESS

PROJECT # 1555

ISSUE DATE 07/07/15

SCALE As indicated

COVER PAGE

**S-000**





REVISIONS

These Drawings have been prepared by Linchpin Structural Engineering, Inc. They are not suitable for use in other projects or locations, or by any other individuals without the written approval and participation of Linchpin Structural Engineering, Inc. Reproduction is prohibited.

**JOSEPH GOV'T  
CENTER ANNEX**

10075 LEVON RD  
TRUCKEE, CA. 96161

DESIGNED BY Designer  
DRAFTED BY Drafter

CLIENT INFORMATION  
NEVADA COUNTY  
CONTACT ADDRESS

PROJECT# 1555

ISSUE DATE 07/07/18

SCALE As indicated

FOUNDATION &  
ROOF FRAMING  
PLAN

**S-100**

**FOUNDATION NOTES**

- 1) SEE TYPED NOTES AND DETAILS ON SHEET S-081 FOR ADDITIONAL INFORMATION.
- 2) SECURE ALL HOLD-DOWN ANCHORS WITHIN FOUR WEEKS PRIOR TO POUR.
- 3) BUILDER SHALL CHECK AND VERIFY ALL DIMENSIONS PRIOR TO CONSTRUCTION.
- 4) WIDEN/EXTEND FOOTINGS AS REQUIRED TO PROVIDE SUPPORT FOR ANY VENEER SHOWN ON ARCHITECTURAL DRAWINGS.
- 5) INSTALL ALL HOLD-DOWN ANCHORS PER MANUFACTURER SPECS & EDGE DISTANCE REQUIREMENTS.

**FOUNDATION & FLOOR FRAMING LEGEND**

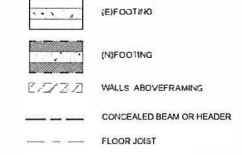

**POST, TRIMMER OR COLUMN**



**FOUNDATION NOTES**

1" = 1'-0"

**ROOF FRAMING NOTES**

- 1) ROOF SHEATHING TO BE 5/8" APART 4020W/104 (0.148 SHANK DIAMETER) @ 12" O.C. BOUNDARY & EDGES AND 12" O.C. FIELD (UNCL). PROVIDE # 2 O.C. NAILING INTO ALL BLOCKING, OUTRIGGERS AND GABLE TRUSSES. SEE DASH-BLOCK NAILING DETAIL ON S-436 FOR MORE INFO.
- 2) SEE ADDITIONAL REQUIREMENTS IN STRUCTURAL SPECIFICATIONS SHEET S-001.

**FRAMING LEGEND**

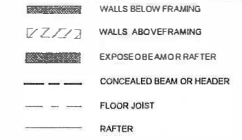

**POST, TRIMMER OR COLUMN**

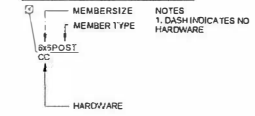

**ROOF FRAMING NOTES**

1" = 1'-0"

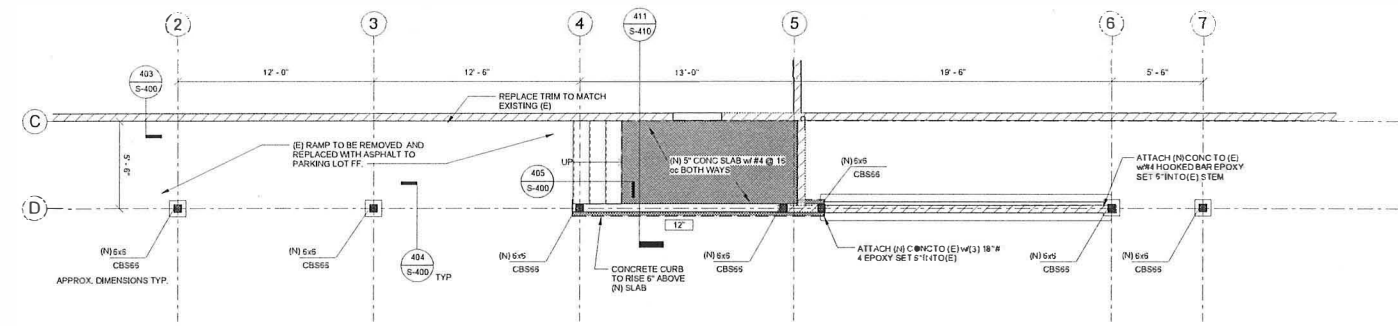

**FOUNDATION PLAN**  
1/4" = 1'-0"

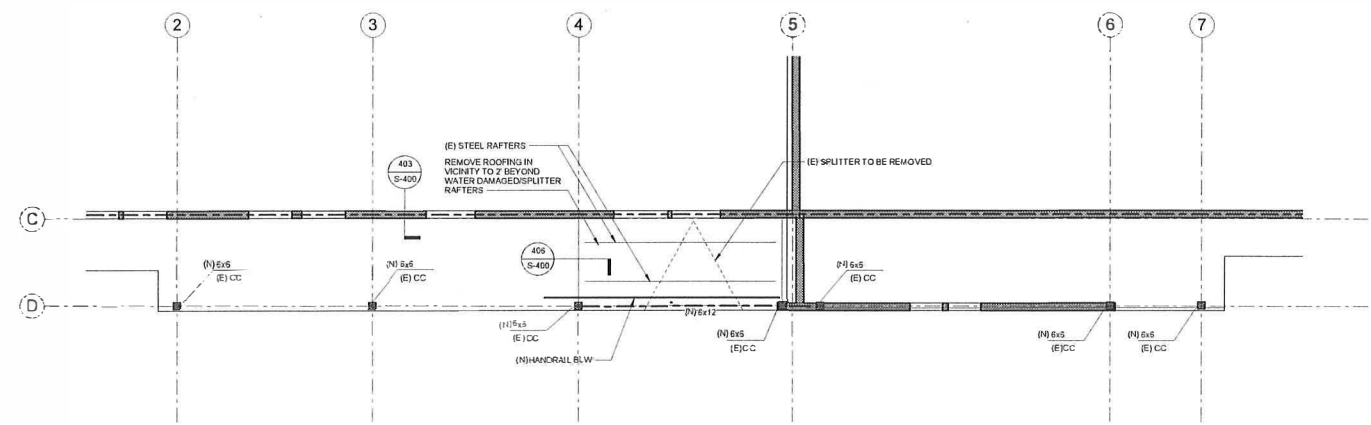

**FRAMING PLAN**  
1/4" = 1'-0"

PRINT DATE 8/4/2018 10:10:21 AM

PRINT DATE: 10/22/16 10:10:22 AM

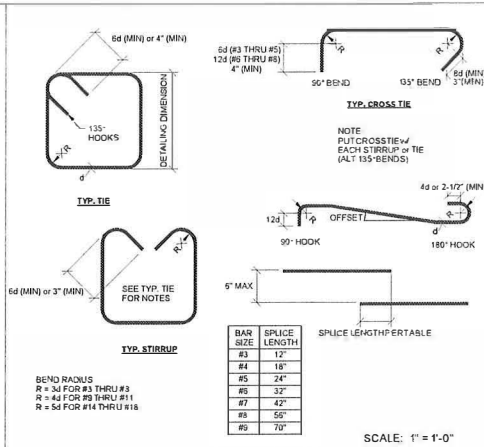
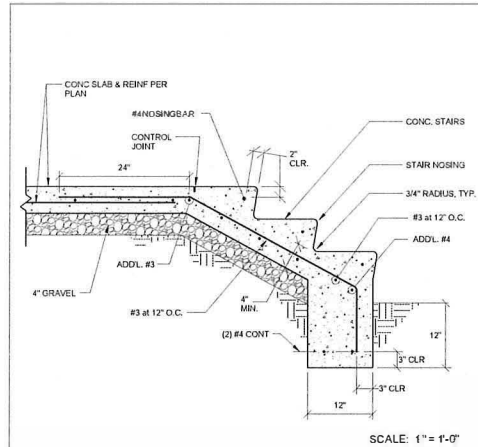

EXTR CONC. STAIR ON GROUND DET 405

TYP BENDS AND HOOKS 402

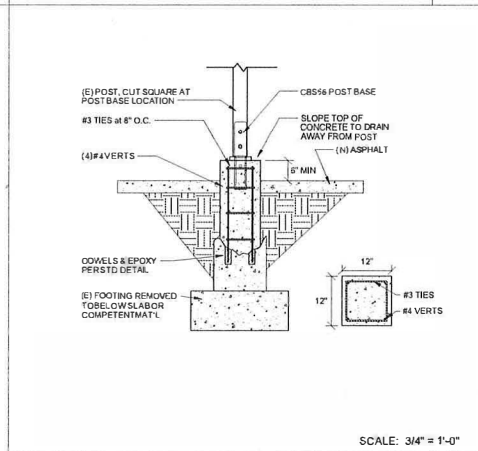
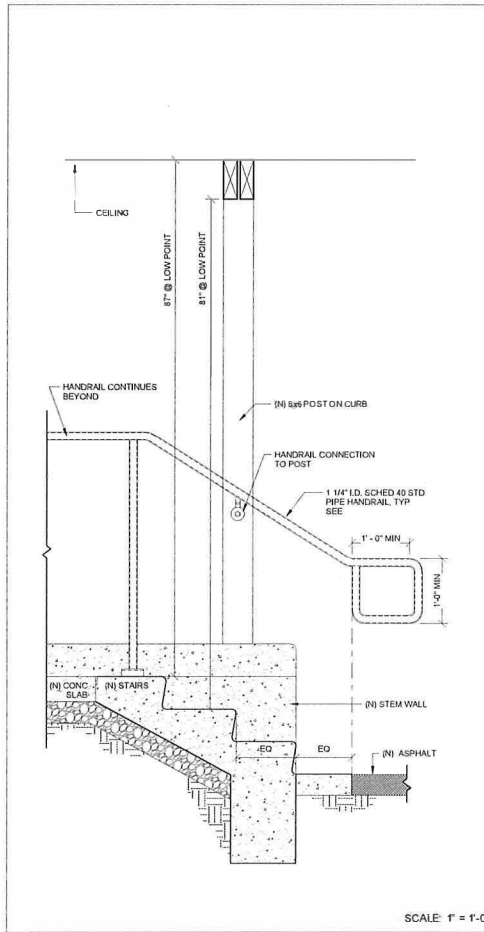

PIER FOOTING DETAIL 404

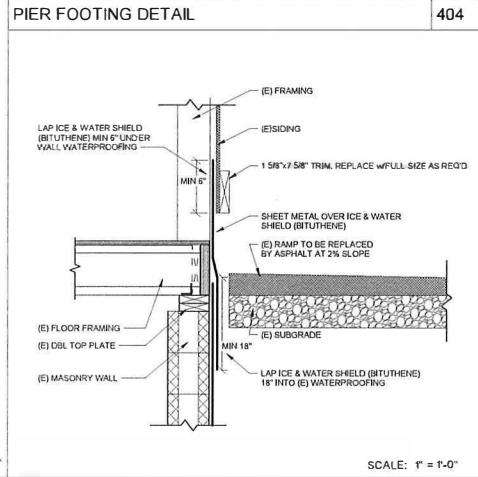
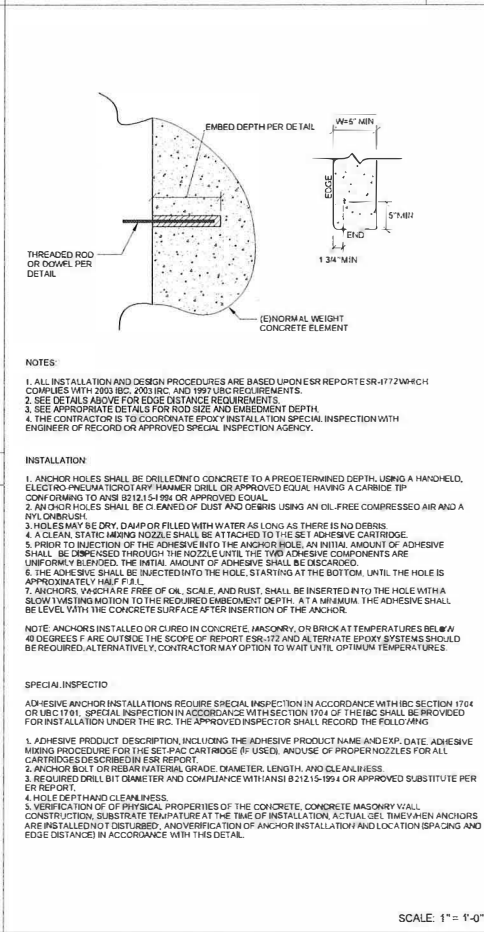

(E) SIDING 403

TYP EPOXY INSTALLATION PROCEDURE 401

**LINCHPIN STRUCTURAL ENGINEERING**  
 10031 West Bove Street, Truckee, CA 96161  
 PO Box 2651, Truckee, CA 96160  
 info@linchpinse.com  
 www.linchpinse.com



REVISIONS

These Drawings have been prepared by Linchpin Structural Engineering Inc. They are not suitable for use on other projects, in other locations, or by any other individuals without the written approval and office of Linchpin Structural Engineering Inc. Reproduction is prohibited.

DESIGNED BY: Designer  
 DRAFTED BY: Drafter

CLIENT INFORMATION  
 NEVADA COUNTY CONTACT ADDRESS

PROJECT#: 1555

ISSUE DATE: 07/07/16

SCALE: As indicated

DETAILS

S-400

JOSEPH GOV'T CENTER ANNEX

10075 LEVON RD TRUCKEE, CA. 96161

PRINT DATE: 8/20/16 10:10:22 AM

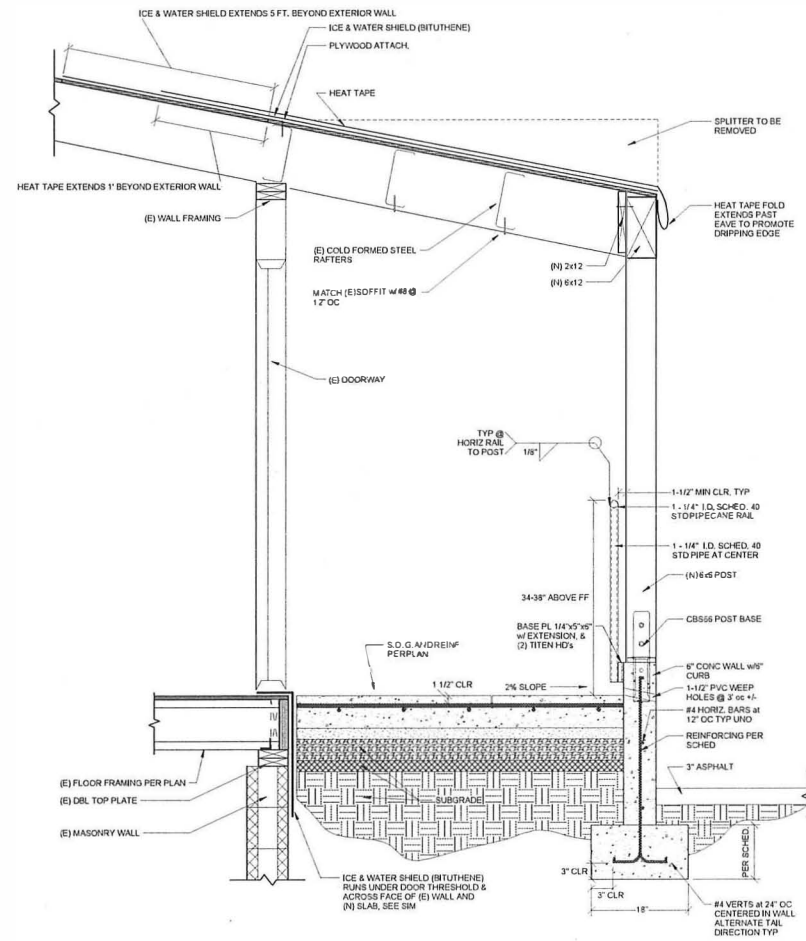

SLAB & ROOF SECTION

SCALE: 1" = 1'-0"

411



REVISIONS

These Drawings have been prepared by Linchpin Structural Engineering Inc. They are a not suitable for use on other projects in other locations or by any other individuals without the written approval and/or signature of a duly Licensed Professional Engineer. Reproduction is prohibited.

**JOSEPH GOV'T CENTER ANNEX**

10075 LEVON RD  
TRUCKEE, CA. 96161

DESIGNED BY Designer  
 DRAFTED BY Drafter

CLIENT INFORMATION  
 NEVADA COUNTY  
 CONTACT ADDRESS

PROJECT# 1555

ISSUE DATE 07/07/16

SCALE 1" = 1'-0"

SECTION DETAILS

**S-410**