



RESOLUTION No. 23-269

OF THE BOARD OF SUPERVISORS OF THE COUNTY OF NEVADA

RESOLUTION AUTHORIZING THE CHAIR OF THE BOARD TO SIGN THE INVITATION TO BID AND THE PURCHASING AGENT TO SOLICIT BIDS FOR ELECTRIC BUS CHARGING PROJECT NEVADA COUNTY OPERATIONS CENTER (NCOC) PHASE-1, CALIFORNIA AIR RESOURCES BOARD (CARB) GRANT G20-NS-001, COUNTY PROJECT NO. 889830, ALL DISTRICTS

WHEREAS, the County of Nevada proposes to install an electric bus charging system at the Nevada County Operations Center; and

WHEREAS, bidding documents have been prepared to accomplish this work; and

WHEREAS, the Director of Public Works may incorporate final changes into the bidding documents; and

WHEREAS, the project is funded by Environmental Protection Agency Fiscal Year 2019-20 Targeted Airshed Grant (EPA-OAR-OAQPS-20-01) funds via sub-grantee contract No. G20-NS-001 with California Air Resources Board (CARB), and by State Transit Assistance (STA) funds, and is included in the proposed Fiscal Year 2023/24 Transit Services budget 4281-91003-707-1000; and

WHEREAS, no budget amendment is necessary and there is no impact to the General Fund; and

WHEREAS, construction is scheduled to begin in summer of 2023.

NOW, THEREFORE, BE IT HEREBY RESOLVED that the Board of Supervisors, of the County of Nevada, State of California:

1. Authorizes the Chair of the Board of Supervisors to sign the Invitation to Bid; and
2. Authorizes the Purchasing Agent to solicit bids for the project; and
3. Authorizes the Chair of the Board of Supervisors to sign the plans; and
4. Authorizes the Public Works Director to incorporate any final changes into the bid documents before advertising for bids

PASSED AND ADOPTED by the Board of Supervisors of the County of Nevada at a regular meeting of said Board, held on the 13th day of June, 2023, by the following vote of said Board:

Ayes: Supervisors Heidi Hall, Edward C. Scofield, Lisa Swarhout, Susan Hoek and Hardy Bullock.

Noes: None.

Absent: None.

Abstain: None.

ATTEST:

JULIE PATTERSON HUNTER
Clerk of the Board of Supervisors

By: 

Edward C. Scofield, Chair

6/13/2023 cc: PW*
AC*

COUNTY OF NEVADA
STATE OF CALIFORNIA

SPECIFICATIONS
FOR

Electric Bus Charging Project
Nevada County Operations Center (NCOC) Phase-1

COUNTY PROJECT NO. 889830

California Air Resources Board (CARB) Grant No. G20-NS-001
A sub-grant of U.S. Environmental Protection Agency 2019 and 2020 Targeted
Air Shed Grant Program #TA98T15301-0 with CARB



BIDS DUE: July 13, 2023

The County will conduct this public bid opening through the following on-line site:
Nevada County is inviting you to a scheduled TEAMS meeting at 2:30 p.m. July 13, 2023

Join on your computer, mobile app or room device

[Click here to join the meeting](#)

Meeting ID: 279 440 301 047

Passcode: oYKvUJ

[Download Teams](#) | [Join on the web](#)

Or call in (audio only)

[+1 530-414-9282, 779789136#](#) United States, Truckee

Phone Conference ID: 779 789 136#

[Find a local number](#) | [Reset PIN](#)

PRE-BID SITE VISIT (RECOMMENDED)

9:00 am, Wednesday June 28, 2023

at

12350 La Barr Meadows Rd. Grass Valley, CA 95949

The County will conduct the Pre-Bid meeting in person.

In addition, the County will host a virtual Pre-Bid meeting for those unable to attend in person.
A link to the virtual meeting is provided in the Bid documents.

(Standard Public Works Contract)

PROFESSIONAL ENGINEERS SIGNATURE PAGE

THE SPECIAL PROVISIONS CONTAINED HEREIN HAVE BEEN PREPARED BY OR UNDER THE DIRECTION OF THE FOLLOWING REGISTERED PERSONS.

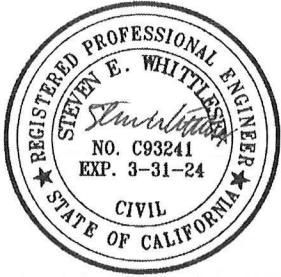

STEVEN WHITTLESEY, REGISTERED CIVIL ENGINEER
(CIVIL ENGINEERING ONLY)



SCOTT WHEELER, REGISTERED ELECTRICAL ENGINEER
(ELECTRICAL ENGINEERING ONLY)

TABLE OF CONTENTS

CONTRACT TIME LINE.....	6
INVITATION TO BID	7
INSTRUCTIONS TO BIDDERS	12
CHECKLIST OF DOCUMENTS ENCLOSED BY BIDDER	21
BID FORM.....	22
BIDDER'S BOND.....	26
EXPERIENCE STATEMENT	28
EXHIBIT 12-B Bidder's List of Subcontractors (DBE and NON-DBE) Part 1.....	29
EXHIBIT 12-B Bidder's List of Subcontractors (DBE and NON-DBE) Part 2.....	30
BIDDER'S REPRESENTATIONS	31
PUBLIC CONTRACT CODE	32
EQUAL EMPLOYMENT OPPORTUNITY CERTIFICATION	33
NONCOLLUSION AFFIDAVIT	34
DEBARMENT AND SUSPENSION CERTIFICATION.....	35
NONLOBBYING CERTIFICATION	36
DISCLOSURE OF LOBBYING ACTIVITIES (SF-LLL).....	37
INSTRUCTIONS FOR COMPLETION OF SF-LLL,.....	38
REQUIRED CONTRACT PROVISIONS FEDERAL-AID CONSTRUCTION CONTRACTS	40
DISADVANTAGED BUSINESS ENTERPRISE (DBE) FORMS	52
EXHIBIT 15-G CONSTRUCTION CONTRACT DBE (MBE) COMMITMENT	53
EXHIBIT 15-G CONSTRUCTION CONTRACT DBE (WBE) COMMITMENT	54
INSTRUCTIONS - CONSTRUCTION CONTRACT DBE COMMITMENT.....	55
INSTRUCTIONS - LOCAL AGENCY BIDDER (EXHIBIT 15-G).....	57
DBE GOOD FAITH EFFORTS	58
EXHIBIT 15-H: PROPOSER/CONTRACTOR GOOD FAITH EFFORTS.....	59
EXHIBIT 9-F: DBE (MBE) RUNNING TALLY OF PAYMENTS.....	62
EXHIBIT 9-F: DBE (WBE) RUNNING TALLY OF PAYMENTS	63
EXHIBIT 9-F INSTRUCTIONS	64
EXHIBIT 17-F FINAL REPORT – UTILIZATION OF DISADVANTAGED BUSINESS ENTERPRISES (DBE) AND FIRST TIER SUBCONTRACTORS - MBE.....	66
EXHIBIT 17-F FINAL REPORT – UTILIZATION OF DISADVANTAGED BUSINESS ENTERPRISES (DBE) AND FIRST TIER SUBCONTRACTORS - WBE	67
EXHIBIT 17-F INSTRUCTIONS	68
EXHIBIT 17-O - DISADVANTAGED BUSINESS ENTERPRISES (DBE) CERTIFICATION STATUS CHANGE.....	69
INSTRUCTIONS - DBE CERTIFICATION STATUS CHANGE	70
FEMALE AND MINORITY GOALS	71
TITLE VI ASSURANCES	73
Equal Opportunity Provisions for Federally Assisted Construction Contracts - 41 CFR 60- 1.4(b).....	75
CARB NONDISCRIMINATION CLAUSES.....	77
FEDERAL TRAINEE PROGRAM.....	78
PROHIBITION OF CERTAIN TELECOMMUNICATIONS AND VIDEO SURVEILLANCE EQUIPMENT AND SERVICES.....	80
FEDERAL WAGE RATES.....	81
COUNTY SPECIAL PROVISIONS	82
SPECIAL PROVISIONS.....	83
DIVISION I GENERAL PROVISIONS.....	83
SECTION 1 GENERAL	83
SECTION 2 BIDDING	84
SECTION 2-2 BID ITEM DESCRIPTIONS	91
SECTION 3 CONTRACT AWARD AND EXECUTION	99
SECTION 4 SCOPE OF WORK.....	101

SECTION 5 CONTROL OF WORK.....	103
SECTION 6-1 CONTROL OF MATERIALS - GENERAL.....	106
SECTION 6-2 CONTROL OF MATERIALS - QUALITY ASSURANCE.....	108
SECTION 7 LEGAL RELATIONS AND RESPONSIBILITY TO THE PUBLIC.....	108
SECTION 8 PROSECUTION AND PROGRESS.....	109
SECTION 9 PAYMENT.....	110
DIVISION II GENERAL CONSTRUCTION.....	112
SECTION 10 GENERAL.....	112
SECTION 12 TEMPORARY TRAFFIC CONTROL.....	112
SECTION 13 WATER POLLUTION CONTROL.....	114
SECTION 14 ENVIRONMENTAL STEWARDSHIP.....	117
DIVISION III EARTHWORK AND LANDSCAPE.....	119
SECTION 19 EARTHWORK.....	119
SECTION 20 LANDSCAPE.....	120
DIVISION IV SUBBASES AND BASES.....	120
SECTION 26 AGGREGATE BASES.....	120
DIVISION V SURFACING AND PAVEMENTS.....	121
SECTION 39 ASPHALT CONCRETE.....	121
SECTION 52 REINFORCEMENT.....	122
SECTION 77-1 TRENCHING AND BACKFILLING.....	122
DIVISION IX TRAFFIC CONTROL DEVICES.....	125
SECTION 84-2 TRAFFIC STRIPES AND PAVEMENT MARKINGS.....	125
SECTION 84-9 EXISTING MARKINGS.....	126
DIVISION X ELECTRICAL WORK.....	127
DIVISION XI MATERIALS.....	127
SECTION 90 CONCRETE.....	127
(Standard Public Works Contract).....	130
PERFORMANCE BOND.....	131
CERTIFICATE OF ACKNOWLEDGEMENT.....	132
PAYMENT BOND.....	133
CERTIFICATE OF ACKNOWLEDGEMENT.....	134
CONTRACT.....	135
ARTICLE I: DEFINITIONS.....	135
ARTICLE II: SCOPE OF WORK.....	138
ARTICLE III: CONTRACT TIME.....	138
ARTICLE IV: CHANGE OF CONTRACT TIME.....	139
ARTICLE V: CONTRACT PRICE.....	140
ARTICLE VI: CHANGE OF CONTRACT PRICE.....	140
ARTICLE VII: PAYMENTS TO CONTRACTOR.....	144
ARTICLE VIII: PRELIMINARY MATTERS.....	148
ARTICLE IX: CHANGES IN THE WORK.....	149
ARTICLE X: CONTRACT DOCUMENTS.....	150
ARTICLE XI: THE PROJECT SITE.....	151
ARTICLE XII: PAYMENT AND PERFORMANCE BONDS.....	153
ARTICLE XIII: CONTRACTOR LIABILITY AND INSURANCE.....	154
ARTICLE XIV: MATERIALS AND EQUIPMENT.....	157
ARTICLE XV: PLANS AND SPECIFICATIONS.....	159
ARTICLE XVI: SHOP DRAWINGS AND SAMPLES.....	160
ARTICLE XVII: SUBCONTRACTORS, SUPPLIERS AND OTHERS.....	161
ARTICLE XVIII: PERFORMANCE OF THE WORK.....	162
ARTICLE XIX: TESTS AND INSPECTIONS.....	171
ARTICLE XX: SUSPENSION OF WORK AND TERMINATION.....	173
ARTICLE XXI COUNTY'S AGENT'S STATUS DURING CONSTRUCTION.....	175
ARTICLE XXII: PARTIAL COMPLETION.....	178
ARTICLE XXIII: ARBITRATION.....	179

ARTICLE XXIV: LABOR AND EMPLOYMENT	179
ARTICLE XXV: ASSIGNMENT.....	181
ARTICLE XXVI: CONFLICT OF INTEREST RESTRICTIONS.....	181
ARTICLE XXVII: WAIVER OF RIGHTS.....	181
ARTICLE XXVIII: SUCCESSORS IN INTEREST	181
ARTICLE XXIX: NOTICE.....	181
ARTICLE XXX: VENUE AND JURISDICTION.....	182

ATTACHMENTS

Attachment 1 – Electrical Specifications

Attachment 2 – ChargePoint Documentation

- Part A - “Express Plus, DC Fast Charging Solution, Site Design Guide”
- Part B - “Express Plus, DC Fast Charging Platform, Installation Guide”
- Part C - Concrete Mounting Template Instructions
- Part D - Express Plus Specifications
- Part E - Packing Slip for Delivered Equipment

Attachment 3 – NCOC Conformed Set

Attachment 4 – Labor Rates

CONTRACT TIME LINE

1. BIDS DUE: **2:30 pm, Thursday July 13, 2023**
2. BID OPENING: **2:30 pm, Thursday July 13, 2023**
3. BIDS TO REMAIN OPEN FOR **60 DAYS** FROM DATE OF OPENING OF BIDS.
4. NOTICE OF AWARD DUE WITHIN **60 DAYS** OF OPENING OF BIDS.
5. BID BONDS OF UNSUCCESSFUL BIDDERS TO BE RETURNED WITHIN **10 DAYS** OF AWARD BY COUNTY.
6. SIGNED CONTRACT AND BONDS DUE WITHIN **30 DAYS** OF NOTICE OF AWARD.
7. NOTICE TO PROCEED WITH WORK WILL BE ISSUED WITHIN **14 DAYS** OF CONTRACT SIGNING.
8. CONSTRUCTION MUST BEGIN WITHIN **7 DAYS** AFTER ISSUANCE OF NOTICE TO PROCEED.
9. CONTRACTOR MUST GIVE **48** HOURS WRITTEN NOTICE OF DATE WORK WILL COMMENCE.
10. PRECONSTRUCTION CONFERENCE WITHIN **7 DAYS** OF NOTICE TO PROCEED.
11. SCHEDULES AND BREAKDOWN OF PHASES OF CONSTRUCTION DUE IN **5 DAYS** AFTER RECEIPT OF NOTICE TO PROCEED.
12. **WORK MUST BE COMPLETED WITHIN 40 WORKING DAYS**

COUNTY OF NEVADA
DEPARTMENT OF PUBLIC WORKS

INVITATION TO BID

FOR:

**Electric Bus Charging Project
Nevada County Operations Center (NCOC) Phase-1**

COUNTY PROJECT NO.: 889830

California Air Resources Board (CARB) Grant No. G20-NS-001

**A sub-grant of U.S. Environmental Protection Agency 2019 and 2020 Targeted
Air Shed Grant Program #TA98T15301-0 with CARB**

**LOCATED AT: Nevada County Operations Center
12350 La Barr Meadows Road, Grass Valley**

Sealed bids will be received at the office of:

Nevada County Purchasing Division
Suite 129
950 Maidu Avenue
PO BOX 599002
Nevada City, CA 95959-7902

Submittals are to be received by mail, or if hand delivered, must be placed in a sealed envelope with the name of the project clearly printed on the front of the envelope and should be delivered to the Purchasing Division in the Eric Rood Administrative Center. All bids will be dated and time-stamped once received by the County representative.

Until 2:30 pm, Thursday, July 13, 2023 local time for the above-referenced project.

Bids received after said time will not be accepted and will be returned unopened.

At said place and time, and promptly thereafter, all bids that have been properly submitted will be publicly opened and read aloud. Bids received after said time will not be accepted and will be returned unopened. All interested parties are invited to attend.

The County will conduct this public bid opening through the following on-line site:

Nevada County is inviting you to a scheduled TEAMS meeting at 2:30 pm, Thursday, July 13, 2023

Join on your computer, mobile app or room device

[Click here to join the meeting](#)

Meeting ID: 279 440 301 047

Passcode: oYKvUJ

[Download Teams](#) | [Join on the web](#)

Or call in (audio only)

[+1 530-414-9282](#), [779789136#](#) United States, Truckee

Phone Conference ID: 779 789 136#

[Find a local number](#) | [Reset PIN](#)

The work to be performed includes the following:

The work to be done, in general, consists of the installation of an owner supplied ChargePoint 150kW Express Plus plug-in charging system to accommodate the charging of two buses at the Nevada County Operations Center (NCOC). The ChargePoint Express Plus system consists of the Power Block charging power supply cabinet and the Power Link dispenser cabinet.

Contractor shall supply/install a new circuit breaker and private meter in the existing NCOC main switchboard (MSB) to serve the charging equipment. Contractor shall connect the meter to the County network in the existing Server Room. Contractor shall furnish and install conduit, conductors, pull boxes, etc. to connect the ChargePoint Power Block to the MSB, and also furnish and install conduit, conductors, cable, pull boxes, vault etc. to connect the Power Block to the Power Link. The Power Link shall be installed within the existing asphalt parking area. Contractor shall construct concrete equipment pads and bollards for the Power Block and Power Link. Contractor shall furnish and install earth ground rods/wells. Contractor shall supply/install empty conduits and pull boxes within the existing parking area to allow for the addition of charging systems in future phases. Contractor shall perform all required trenching and excavation, including reinstatement of paved areas with hot mix asphalt and unpaved areas with aggregate base. Contractor will remove existing striping, lay out the bus charging spaces and provide painted parking stripes.

If possible, all work shall be completed without interruption of power supply to the NCOC. If power supply must be interrupted to complete the work, the contractor shall inform the engineer a minimum of 72 hours in advance so appropriate arrangements can be made.

This project has been funded wholly or in part by the United States Environmental Protection Agency under assistance agreement number TA98T15301-0 to the California Air Resources Board. The contents of this document do not necessarily reflect the views and policies of the U.S. Environmental Protection Agency, nor does U.S. EPA endorse trade names or recommend the use of commercial products mentioned in this document.

Bids shall be **UNIT PRICES**

Bids must be for all of the work described herein unless the Bid Form specifically indicates a bid item is optional.

Complete work within **40** working days.

The Engineer's Estimate for this contract is \$240,000.

DBE Requirements

Although this project is funded by an EPA Assistance Agreement, for tracking of DBE utilization, in this case Minority Business Enterprise (MBE) and Women Business Enterprise (WBE), the Caltrans DBE approach and forms (modified) shall be used.

The MBE contract goal is **2 percent**

The WBE contract goal is **1 percent**

"Buy America"

This project is subject to the "Buy America" provisions of the Surface Transportation Assistance Act of 1982 as amended by the Intermodal Surface Transportation Efficiency act of 1991.

Domestic Preference Requirements

Domestic Preference requirements are found in 2 CFR 200.322. Under 2 CFR 200.322(a), to the extent consistent with law, Contractor and Subcontractors should, to the greatest extent practicable under a Federal award, provide a preference for the purchase, acquisition, or use of goods, products, or materials produced in the United States (including but not limited to iron, aluminum, steel, cement, and other manufactured products).” The regulation provides definitions of the terms “Produced in the United States” and “Manufactured products” at 2 CFR 200.322(b).

Recovered Materials

As provided in 2 CFR 200.223, Contractor and Subcontractors shall comply with section 6002 of the Solid Waste Disposal Act, as amended by the Resource Conservation and Recovery Act. The requirements of Section 6002 include procuring only items designated in guidelines of the Environmental Protection Agency (EPA) at 40 CFR part 247 that contain the highest percentage of recovered materials practicable. This requirement applies when it is consistent with maintaining a satisfactory level of competition, where the purchase price of the item exceeds \$10,000 or the value of the quantity acquired during the preceding fiscal year exceeded \$10,000.

Obtaining Contract Documents: Official copies of the Contract Documents for bidding may be downloaded free of charge at the following link: www.mynevadacounty.com/purchasing. Alternatively, these documents may be purchased for approximately \$40.00 in person at the Purchasing Division, 950 Maidu Ave, Nevada City, CA 95959 if arranged and confirmed in advance.

Questions regarding the Work or the contract Documents shall be submitted online on Public Purchase.

Contractor will be required to possess a **CLASS A** contractor’s license or a **combination of classes required by the categories and types of work** included in this contract at the time the bid is submitted. The contractor must be properly licensed as a contractor from contract award through contract acceptance (Public Contract Code § 10164).

A pre-bid walk-through will be held beginning at 9:00 am, Wednesday, June 28, 2023 at the project site at:

Nevada County Operations Center
12350 La Barr Meadows Rd.
Grass Valley, CA 95949

The County will conduct the Pre-Bid meeting in person.

In addition, the County will host a virtual Pre-Bid meeting for those unable to attend in person.

A link to the virtual meeting is provided below:

Join on your computer, mobile app or room device

[Click here to join the meeting](#)

Meeting ID: 274 568 261 108

Passcode: 7g28AU

[Download Teams](#) | [Join on the web](#)

Or call in (audio only)

[+1 530-414-9282](tel:+15304149282), [833772242#](tel:+1833772242) United States, Truckee

Phone Conference ID: 833 772 242#

[Find a local number](#) | [Reset PIN](#)

DEPARTMENT OF INDUSTRIAL RELATIONS CONTRACTOR REGISTRATION. The Department of Industrial Relations (DIR) has launched an online application at <https://www.dir.ca.gov/Public-Works/Contractor-Registration.html> for public works contractors to meet the requirements of Senate Bill 854. Contractors must register and meet requirements using the new online application before bidding on public works contracts in California.

Contractor and subcontractors shall be bound by all applicable provisions of California Labor Code Section 1771.

In accordance with California Labor Code Section 1771.1, a contractor or subcontractor shall not be qualified to bid on, be listed in a Bid Form, subject to the requirements of Section 4104 of the Public Contract Code, or engage in the performance of any contract for public work, as defined in this chapter, unless currently registered and qualified to perform public work pursuant to Section 1725.5. Bids cannot be accepted from unregistered contractors except as provided in Section 1771.1.

Contractor and all subcontractors must comply with the requirements of labor code Section 1771.1(a), pertaining to registration of contractors pursuant to Section 1725.5 Registration and all related requirements of those Sections must be maintained throughout the performance of the contract.

This project is subject to compliance monitoring and enforcement by the Department of Industrial Relations. Each contractor and subcontractor must furnish certified payroll records to the Labor Commissioner at least monthly.

The County is required to provide notice to the Department of Industrial Relations of any public works contract subject to prevailing wages within five (5) days of the award. The County of Nevada encourages its contractors and subcontractors to use the US. Citizenship and Immigration Services E-Verify system to verify that employees are eligible to work in the United States. Information about the E-Verify system is available at www.dhs.gov/e-verify.

Each bidder must submit a cashier's check, certified check or a bidder's bond in an amount equal to 10% of the total amount of the bid. The bidder to whom a contract is awarded will be required to furnish a performance bond and a payment bond guaranteeing faithful performance and payment of all debts related to this contract.

The County of Nevada, in accordance with Title VI of the Civil Rights Act of 1964 (78 Stat. 252) and the regulations of the Department of Commerce (15 C.F.R., Part 8), issued pursuant to such Act, hereby notifies all bidders that it will affirmatively ensure that in any contract entered into pursuant to this advertisement, minority business enterprises will be afforded full opportunity to submit bids in response to this invitation and will not be discriminated against on the grounds of race, color, or national origin in consideration for an award.

This is a public works project. Pursuant to Sections 1770 and 1773 of the Labor Code of the State of California, the County of Nevada has ascertained that prevailing wage rates are applicable to the work to be done and are available at the State of California Department of Industrial Relations website <http://www.dir.ca.gov/dlsr/PWD/index.htm>. Contractor shall not pay less than the prevailing rate of wages.

No bid will be considered unless it is made on a blank form furnished by the County of Nevada and is made in accordance with the provisions of the bid requirements and conditions set forth in the contract documents.

Attention is directed to the Federal minimum wage rate requirements in the Bid Book. If there is a difference between the minimum wage rates predetermined by the Secretary of Labor and the

general prevailing wage rates determined by the Director of the California Department of Industrial Relations for similar classifications of labor, the Contractor and subcontractors shall pay not less than the higher wage rate. The Department will not accept lower State wage rates not specifically included in the Federal minimum wage determinations. This includes "helper" (or other classifications based on hours of experience) or any other classification not appearing in the Federal wage determinations. Where Federal wage determinations do not contain the State wage rate determination otherwise available for use by the Contractor and subcontractors, the Contractor and subcontractors shall pay not less than the Federal minimum wage rate which most closely approximates the duties of the employees in question.

The salary rate (excluding overhead) paid to individual consultants retained by Contractor or Subcontractors shall be limited to the maximum daily rate for a Level IV of the Executive Schedule, available at <https://www.opm.gov/policy-data-oversight/pay-leave/salaries-wages>, to be adjusted annually. This limit applies to consultation services of designated individuals with specialized skills who are paid at a daily or hourly rate. This rate does not include transportation and subsistence costs for travel performed (the recipient will pay these in accordance with their normal travel reimbursement practices). Sub-agreements with firms for services which are awarded using the procurement requirements in Subpart D of 2 CFR 200 are not affected by this limitation unless the terms of the contract provide the recipient with responsibility for the selection, direction, and control of the individuals who will be providing services under the contract at an hourly or daily rate of compensation.

The U.S. Department of Transportation (DOT) provides a toll-free "hotline" service to report bid rigging activities. Bid rigging activities can be reported Mondays through Fridays, between 8:00 a.m. and 5:00 p.m., Eastern Time, Telephone No. 1-800-424-9071. Anyone with knowledge of possible bid rigging, bidder collusion, or other fraudulent activities should use the "hotline" to report these activities. The "hotline" is part of the DOT's continuing effort to identify and investigate highway construction contract fraud and abuse and is operated under the direction of the DOT Inspector General. All information will be treated confidentially, and caller anonymity will be respected.

County reserves the right, acting in its sole discretion, to waive immaterial bid irregularities, to accept or reject any and all bids, or to abandon the Project entirely.

COUNTY OF NEVADA
STATE OF CALIFORNIA

By: 
Chair, Board of Supervisors or Purchasing Agent

Dated: 6/13/23

NEVADA COUNTY DEPARTMENT OF PUBLIC WORKS
 CIVIL ENGINEERING PLANS FOR THE CONSTRUCTION OF
ELECTRIC BUS CHARGING PROJECT NCOC PHASE-1
 NEVADA COUNTY OPERATIONS CENTER (NCOC)
 12350 LA BARR MEADOWS ROAD, GRASS VALLEY, CALIFORNIA
 COUNTY PROJECT NO. 889830

FUNDED BY:
 CALIFORNIA AIR RESOURCES BOARD (CARB) GRANT NO. G20-NS-001
 A SUB GRANT OF U.S. ENVIRONMENTAL PROTECTION AGENCY 2019 AND 2020 TARGETED AIR SHED GRANT PROGRAM #TA98T15301-0 WITH CARB

SITE LOCATION

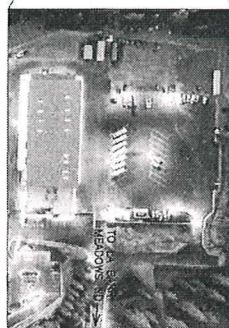
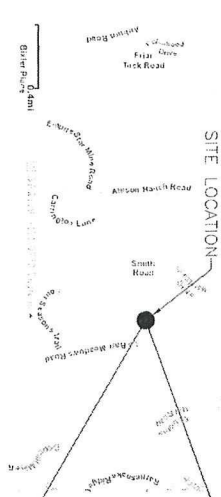
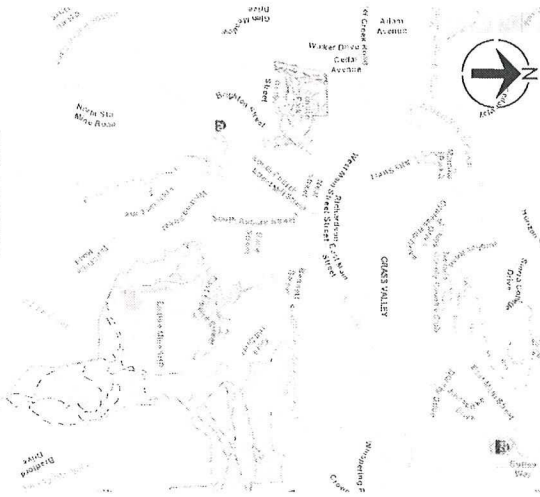

SITE PLAN
 NTS

SHEET INDEX

SHEET	TITLE
C001	TITLE SHEET
C002	EXISTING CONDITIONS
C101	EXISTING CONDITIONS
C102	SITE PLAN
C201	DETAILS 1
C202	DETAILS 2
C301	(ELECTRICAL PLANS)
C302	COVER SHEET
E1.01	STANDARD SPECIFICATIONS
E1.02	ENLARGED PLAN
E2.01	DETAILS

NOTICE TO CONTRACTOR

48 HOURS NOTICE REQUIRED PRIOR TO COMMENCING WORK BEFORE COMMENCING WORK. ALL REQUIRED PLANS, SCHEDULES PROGRAMS AND OTHER SUBMITTALS MUST BE SUBMITTED AND APPROVED IN ACCORDANCE WITH THE CONTRACT STIPULATIONS DATED 2018. THE CONTRACT DOCUMENTS AND SPECIAL PROVISIONS, BEFORE COMMENCING WORK THE CONTRACTOR SHALL NOTIFY THE NEVADA COUNTY DEPARTMENT OF PUBLIC WORKS 48 HOURS IN ADVANCE OF THE TIME OF COMMENCEMENT.

PROJECT CONTACTS

AGENCY	CONTACT	PHONE	EMAIL
OWNER NEVADA COUNTY COMMERCE + NEVADA COUNTY NOW	ROBIN VAN VALKENBURGH	530-470-2833	robin.vanvalkenburgh@nevadacounty.gov
DEAL ENGINEER/OWNER NEVADA COUNTY	RICHARD POOLE (PROJECT MANAGER)	530-913-1028	rpoole@nevadacounty.gov
ELECTRICAL ENGINEER THE ENGINEERING ENTERPRISE	SCOTT WHEELER	530-305-4717	scott@engent.com
CHASSIS/EQUIPMENT VENDOR CHARGEPON	MARIA BROWN	478-597-6033	maria.brown@chargepoint.com
UTILITIES PLATE	LEE WELLS	530-320-3908	lw@psg.com
AT&T	LEE WELLS	916-505-7308	lw@att.com
NEVADA IRRIGATION DISTRICT (NID)	CAMERON PRICE	530-273-6185	price@nidwater.com

Richard Poole 5/24/23
 Project Manager, PE 57697
 Principal Civil Engineer, Department of Public Works

Hilda E. Guinday 5/12/23
 Director, Department of Public Works

Shirley A. Ferguson 6/15/23
 Chief, Board of Supervisors



Electric Bus Charging Project
 NCOC Phase-1
TITLE SHEET

Nevada County - Department of Public Works



No.	Description	By	Date

Date:	
Designed:	RP SM
Drawn:	SW JP
Checked:	SW JP
Job No.:	89830
Date:	May 24, 2023
Scale:	Reference 1"=1"
Drawings:	C001

SCALE 1" = 20'



- LEGEND**
- PULL BOX
 - LP 24" LIGHT POLE BASE
 - HB HOSE BIBB
 - C CONDUIT
 - GAS PRESSURE REGULATOR
 - WALL MOUNTED LUMINAIRE
 - BRANCH CIRCUIT FOR 208V, 3-PHASE 200 AMP SERVICE FROM TRANSFORMER AND LOOP SENSOR HOWE RUMBLE TO PANEL - PATH NOT KNOWN
 - HYDRANT

- EXISTING FACILITY LINELETTERS**
- SAN — SANITARY SEWER
 - STM — STORMWATER SEWER
 - GAS — GAS
 - W — WATER
 - E — ELECTRICAL
 - JU — JOINT TRENCH CONDUIT
 - LIGHTING CIRCUIT EXACT PATH NOT KNOWN
 - IRRIGATION
 - FENCE GATE
 - PARKING STRIPE
 - PARKING STRIPE TO BE REMOVED

- NUMBERED NOTES**
- ① TO BE RELOCATED BY COUNTY
 - ② PLANTED AREAS HAVE IRRIGATION EMITTERS AT TREES AND SHRUBS FED BY BLACK POLY TUBING. PROTECT IN PLACE OR RELOCATE, AND RESISTIVE AS NEEDED. SEE GENERAL NOTES.
 - ③ EXISTING AGGREGATE BASE SURFACED/BARE EARTH AREA

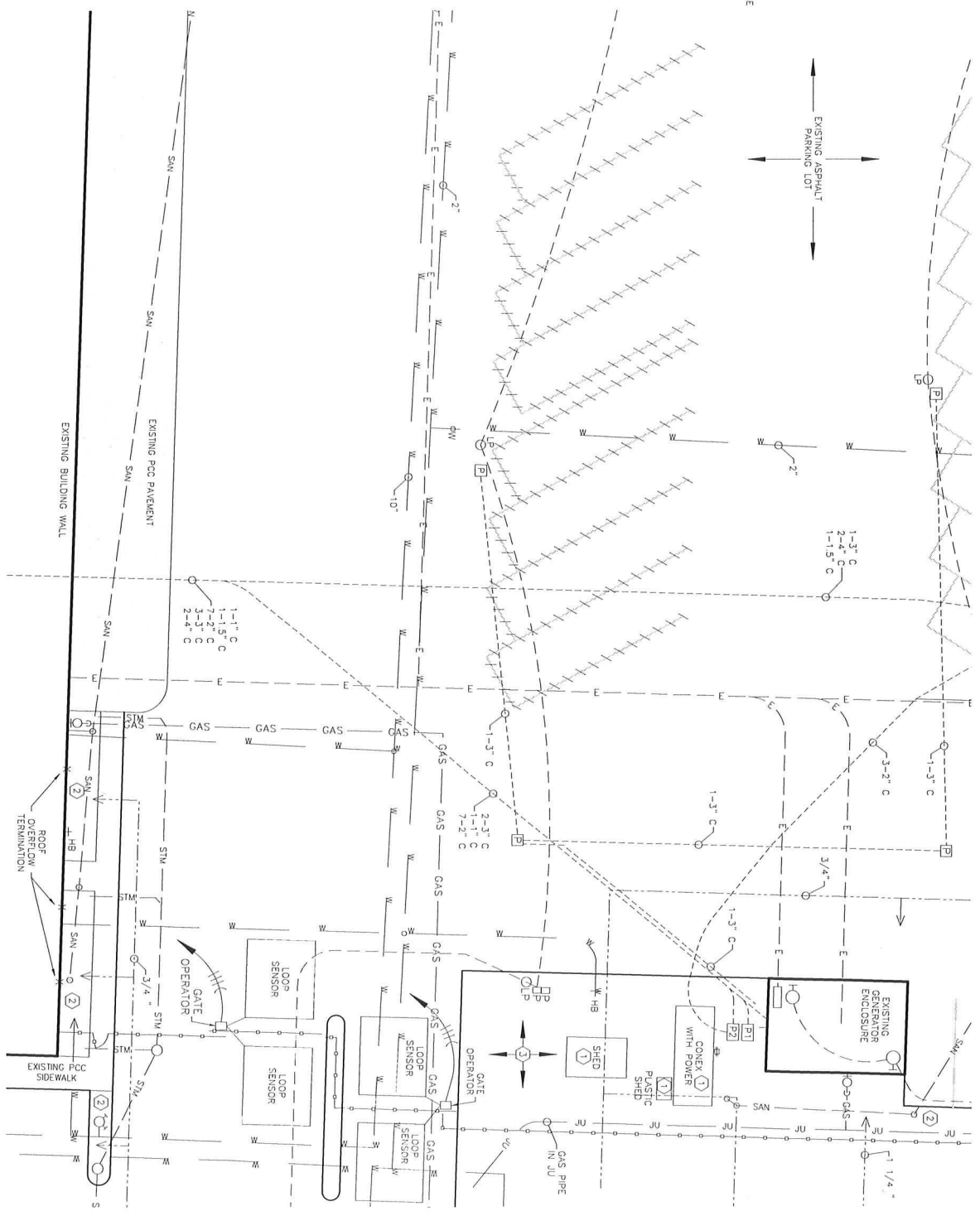

No.	Description	By	Date

Electric Bus Charging Project
NCOC Phase-1
EXISTING CONDITIONS

Nevada County – Department of Public Works

Date: _____
 Designed: RP, SW
 Drawn: RP
 Checked: SW, RP
 Job No: 899330
 Date: May 24, 2023
 Scale Reference: 1" = 20'
 Drawing: C101





SCALE 1" = 20'

- LEGEND**
- PULL BOX (POWER/SIGNAL)
 - 24" LIGHT POLE BASE
 - HOSE BIB
 - CONDUIT
 - GAS PRESSURE REGULATOR
 - WALL MOUNTED LUMINAIRE
 - BRANCH CIRCUIT FOR 208V
 - 3-PHASE 2HP GATE
 - OPERATOR/CONTROLLER AND TO PANEL - PATH NOT KNOWN
 - HYDRAUNT

- STAGING AREA, SEE CS02 NOTE 36
- SOLAR CANOPY COLUMN CONSTRUCTION AREA

- EXISTING FACILITY LINETYPES**
- SANITARY SEWER
 - STORMWATER SEWER
 - GAS
 - WATER
 - ELECTRICAL
 - JOINT TRENCH
 - CONDUIT
 - LIGHTING CIRCUIT EXACT PATH NOT KNOWN
 - IRRIGATION
 - FENCE/GATE
 - PARKING STRIPE
- NEW FACILITY LINETYPES**
- ELECTRICAL
 - ETHERNET/LOW VOLTAGE
 - 4" WHITE PAINT PARKING STRIPE
 - POWER LINK LAYOUT
 - SPRING LAYOUT

- NUMBERED NOTES - PHASE 1, REFER TO ELECTRICAL PLANS FOR DETAILS**
- 1 (N) OFCI POWER BLOCK, F&I ASSOCIATED (N)GROUNDING EQUIP
 - 2 (N) OFCI POWER LINK, F&I ASSOCIATED (N)GROUNDING EQUIP, REFER TO DETAIL 1/CS01
 - 3 (N) (N)CONDUCTORS IN (E)3" TO CONNECT (N)POWER BLOCK TO (N)PB AT (E)MSB
 - 4 (N) (N)C & (N)CONDUCTORS TO CONNECT (N)POWER BLOCK VIA (N)PB SPRUCE TO (E)MSB IN (E)P1
 - 5 (N) (N)C & (N)CONDUCTORS TO CONNECT (N)POWER BLOCK TO (N)POWER LINK VIA (N) VAULT & (N)PB
 - 6 (N) (N)C FOR (E)3" SEE ELECTRICAL PLANS FOR SIZE & NUMBER OF EMPTY (N)C TO PROVIDE
 - 7 (N) (N)VAULT
 - 8 (N) (N)VAULT
 - 9 SEE TRENCH DETAIL 2/CS02 (TYPICAL THROUGHOUT)
 - 10 (N) (N)BO/LAND REFER TO DETAIL 5/E2.01
 - 11 (N) (N)GROUND ROD IN GROUND WELL
 - 12 CENTERLINE OF (N) POWER LINK & PAD
 - 13 END OF (N)STRIPING AT THIS LINE, PARALLEL TO BUILDING & ALIGNED WITH ASPHALT CORNERS
 - 14 KEEP AREA CLEAR FOR (E) SOLAR CANOPY COLUMNS
 - 15 POHOLE TO LOCATE UTILITIES AS NEEDED, SEE SPECIAL PROVISIONS (TYPICAL THROUGHOUT)
 - 16 LAYOUT SHALL BE WITH REFERENCE TO LINE (E) AND THE (E) LIGHT POLE BASE. DO NOT SCALE FROM DRAWINGS FOR LAYOUT. LOCATIONS SHALL BE VERIFIED BY FIELD SURVEY AND FINAL INSTALLATION.
 - 17 (N) (N)C & (N)VAULT & LOW VOLTAGE CABLES TO CONNECT (N)POWER BLOCK TO (N)POWER LINK VIA (N)PB
 - 18 TERMINATE (N)C FOR ETHERNET/LOW VOLTAGE UNDERGROUND IN AREA SOUTH OF PB THAT WILL BE FRENCHED FOR (E)CONNECTION OF (E)POWER LINK CONDUIT. PROVIDE PULL ROPE & MARKER.
- NUMBERED NOTES - PHASE 2, NOT TO BE CONSIDERED**
- 1 ALLOW SPACE FOR THEIR CONSTRUCTION WHEN LAYING OUT AND CONSTRUCTING PHASE-1. SEE ELECTRICAL PLANS
 - 2 (E) UTILITY TRANSFORMER PAD AND BOLLARDS BY POKE
 - 3 (E) PHASE-2 HOUSEKEEPING PAD AND SWITCHGEAR, SEE E1.01
 - 4 (E) EVCS COMPONENTS

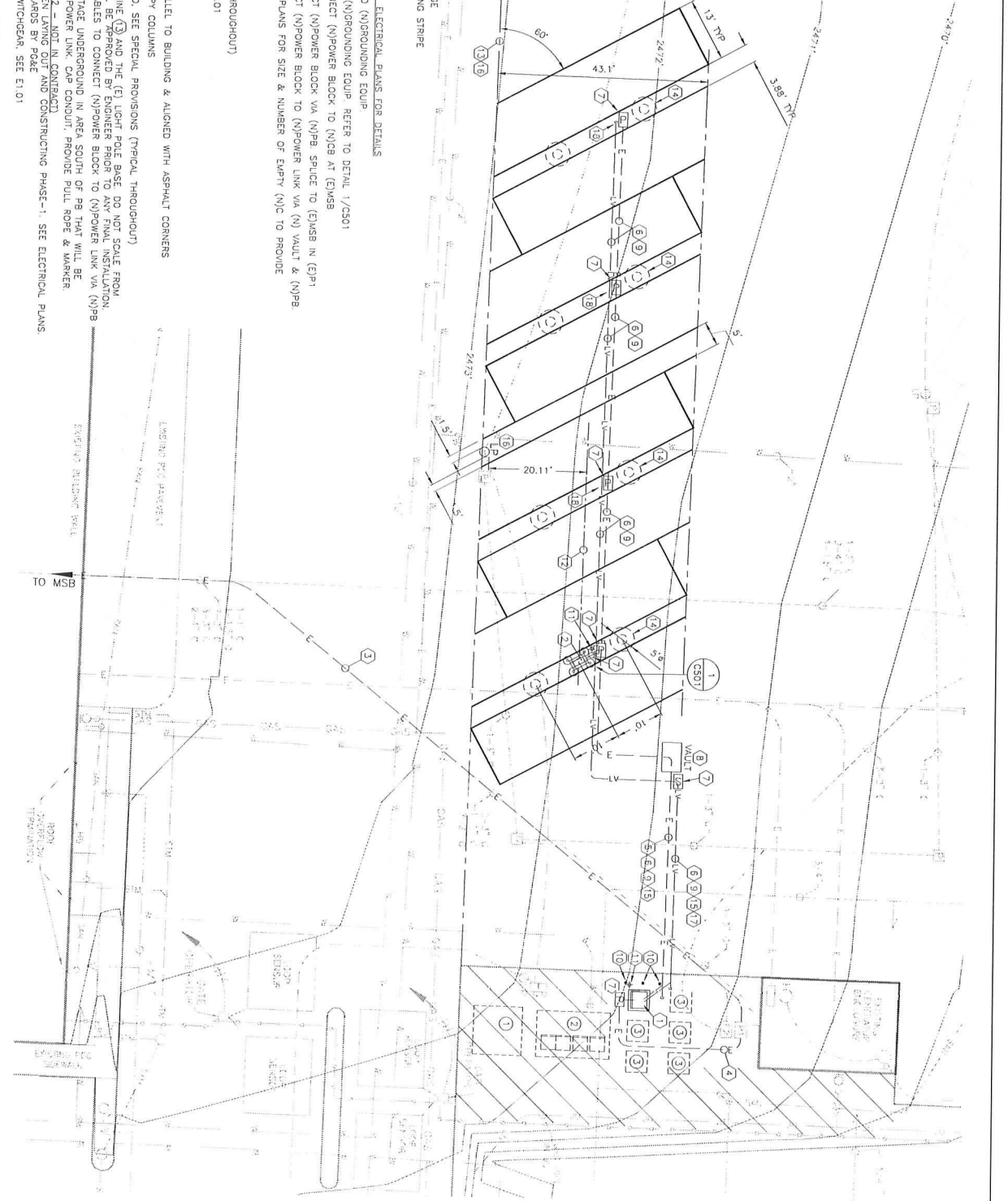

DATE: _____
 DESIGNED: RP SW
 DRAWN: SW SP
 CHECKED: SW SP
 JOB NO.: 889530
 DATE: MAY 24, 2023
 SCALE REFERENCE: 1" = 20'

**Electric Bus Charging Project
 NCOC Phase-1
 SITE PLAN**

Nevada County - Department of Public Works



No.	Description	By	Date

Revisions

Drawing
C102

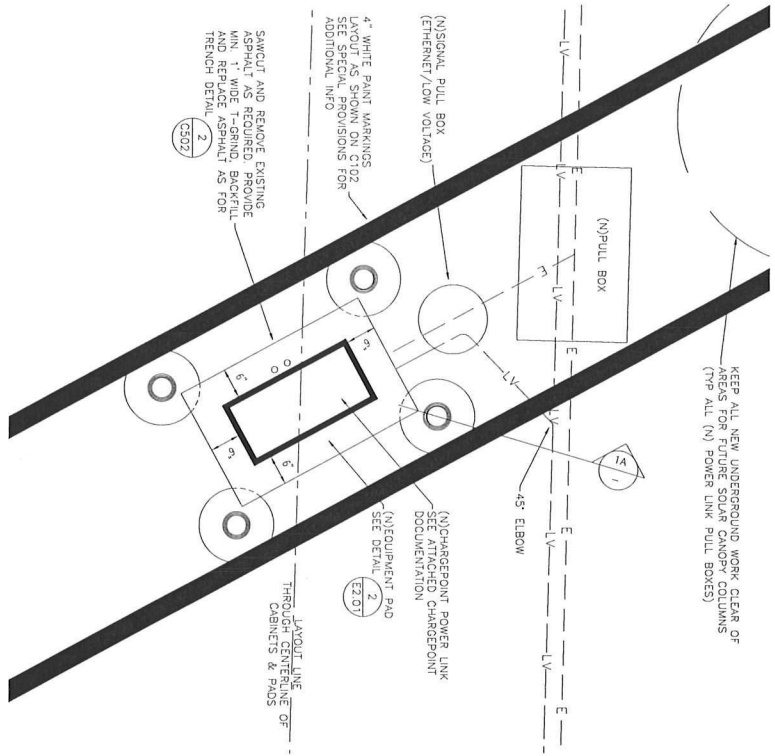

KEEP ALL NEW UNDERGROUND WORK CLEAR OF AREAS FOR FUTURE SOLAR CANOPY COLUMNS (TYP ALL (N) POWER LINK PULL BOXES)

1 DETAIL - EQUIPMENT PAD WITH REMOVABLE BOLLARD

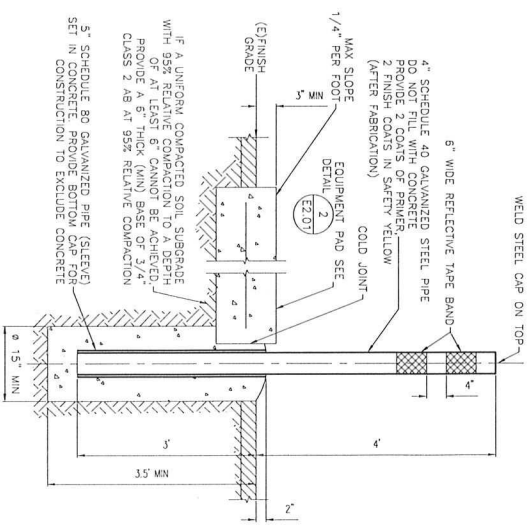

NOTES:
 1. POST SHALL BE REMOVABLE FROM SLEEVE
 2. CONCRETE PER SECTION 90 OF THE SPECIFICATIONS
 3. CONCRETE MOUNTING TEMPLATES AND CONDUIT PENETRATIONS SHALL BE PLACED IN ACCORDANCE WITH THE ATTACHED CHARGEPOINT DOCUMENTATION

SHEET INDEX

1A SECTION - EQUIPMENT PAD WITH REMOVABLE BOLLARD

No.	Description	By	Date



Electric Bus Charging Project
 NCOC Phase-1
 DETAILS 1

Nevada County - Department of Public Works

Date: _____
 Designed: gp SW
 Drawn: RP
 Checked: SW RP
 Job No.: 899330
 Date: May 24, 2023
 Scale Reference: 1/4" = 1'-0"

Drawing
 C501

PAVED AREA

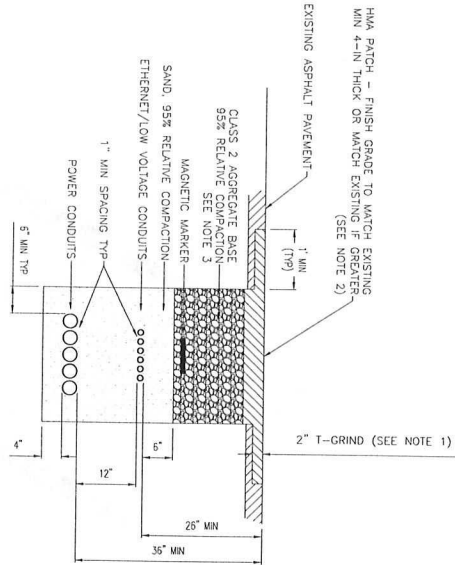

DETAIL NOTES

1. AFTER BACKFILLING TRENCH AS DETAILED, PROVIDE A SAND CUSHION 2-IN DEEP IN UNPAVED PATCH BY SAM CUTTING 2-IN DEEP IN EXISTING ASPHALT PATCH BY DEEP AND 1-FT WIDE CUT/GROUND PAGES SHALL BE COATED WITH TYPE 3 SEAL COAT OR SEAL COAT WITH SAND BEFORE PLACEMENT OF ASPHALT PATCH.
2. HOT MIX ASPHALT SHALL BE INSTALLED ACCORDING TO SECTION 39 OF THE SPECIFICATIONS.
3. SURVEY GROUND MAY BE SUBSTITUTED FOR CLASS 2 AGGREGATE SAND OR SAND CUSHION OPTION. CEMENT SHALL BE PER CALTRANS STANDARD SPECIFICATIONS 19-3.02E.

UNPAVED AREA/NATURAL GROUND

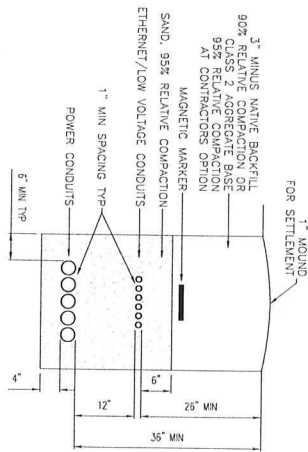

DETAIL NOTES

4. IF TRENCH IN UNPAVED AREA IS ADJACENT TO EXISTING PAVED AREA, PROVIDE A MINIMUM 2-FT WIDE AND 6-IN DEEP SHOULDER STRIP OF CLASS 2 AGGREGATE BASE COMPACTED TO 95% RELATIVE COMPACTION.
5. IF EXISTING UNPAVED AREA IS SURFACED WITH AGGREGATE BASE, REPLACE TO MATCH EXISTING AFTER TRENCHING.

6. UTILITY CROSSINGS OR CLOSE PROXIMITY BETWEEN NEW CONDUITS AND EXISTING UTILITIES WHERE NEW CONDUIT CROSSES OR IS PLACED WITHIN 1-FT OF EXISTING UTILITIES, PROVIDE COMPACTED SAND BACKFILL AS A CUSHION BETWEEN EXISTING UTILITIES AND NEW CONDUITS UNLESS OTHERWISE DIRECTED BY ENGINEER.
7. THE NUMBER OF CONDUITS VARIES DEPENDING UPON THE SECTION OF TRENCH. SEE ELECTRICAL PLANS.



No.	Description	By	Date



Electric Bus Charging Project
NCOC Phase-1
DETAILS 2

Nevada County – Department of Public Works



Date:	
Designed:	RP SW
Drawn:	RP
Checked:	SW Pp
Job No.:	859930
Date:	May 24, 2023
Scale Reference:	1" = 1'

Drawing
C502